

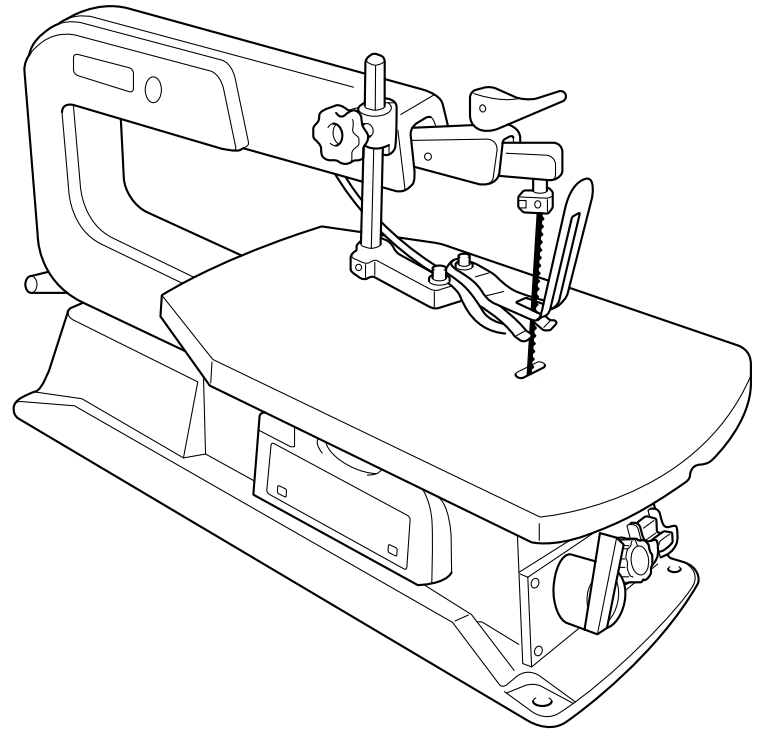

# 16" Variable speed Scroll saw

**SJ401**



**INSTRUCTION MANUAL**  
**IMPORTANT:** Read Before Using.

# SPECIFICATIONS

Throat	406 mm
Blade length	125 mm
Stroke per minute	400-1,600
Overall length	600 mm
Net weight	14.1kg

\* Manufacturer reserves the right to change specifications without notice.

\* Note: Specifications may differ from country to country.

**WARNING: For your personal safety, READ and UNDERSTAND before using.**

**SAVE THESE INSTRUCTIONS FOR FUTURE REFERENCE**

## Contents

<b>General Safety Rules</b> .....	2
<b>Special Safety Rules for Scroll Saw</b> .....	3
<b>Unpacking and Checking Contents</b> .....	4
<b>Getting To Know Your Scroll Saw</b> .....	5
<b>Glossary of Terms</b> .....	6
<b>Assembly &amp; Adjusting</b> .....	6
MOUNTING SCROLL SAW TO WORKBENCH .....	6
SETTING THE TABLE FOR HORIZONTAL OR	
BEVEL CUTTING .....	7
ADJUSTING HOLD DOWN .....	7
ADJUSTING DUST BLOWER .....	7
ALIGNING THE BEVEL INDICATOR .....	7
INSTALLING PIN END BLADES .....	8
INSTALLING PLAIN END BLADES .....	8
REMOVING PLAIN END BLADES .....	8
SPEED CONTROL KNOB/ON-OFF SWITCH .....	9
<b>Basic Scroll Saw Operation</b> .....	9
MAKING INTERIOR SCROLL CUTS .....	10
BEFORE EACH USE: .....	10
CHOICE OF BLADE AND SPEED .....	10
<b>Maintaining Your Scroll Saw</b> .....	11
<b>Trouble Shooting</b> .....	12

## General Safety Rules

- 1. Know Your Power Tool**  
Read and understand the owner's manual and labels affixed to the tool. Learn its application and limitations as well as the specific potential hazards peculiar to this tool.
- 2. Ground all Tools**  
This tool is equipped with an approved 3-conductor cord and a 3-prong grounding type plug to fit the proper grounding type receptacle. The green conductor in the cord is the grounding wire. Never connect the green wire to a live terminal.
- 3. Keep Work Area Clean**  
Cluttered areas and benches invite accidents. Floor must not be slippery due to wax or sawdust.
- 4. Avoid Dangerous Environment**  
Don't use power tools in damp or wet locations or expose them to rain. Keep work area well lighted. Provide adequate surrounding work space.
- 5. Keep Guards in Place**  
In working order, and in adjustment and alignment.
- 6. Remove Adjusting keys and Wrenches**  
Form a habit of checking to see that keys and adjusting wrenches are removed from tool before turning it on.
- 7. Keep Children Away**  
All visitors should be kept a safe distance from work area.
- 8. Make Workshop Child Proof**

- With padlocks, master switches, or by removing starter keys.
- 9. Don't Force Tool**  
It will do the job better and safer at the rate for which it was designed.
  - 10. Never Stand on Tool**  
Serious injury could occur if the tool is tipped or if the cutting tool is accidentally contacted.  
Do not store materials above or near the tool such that it is necessary to stand on the tool to reach them.
  - 11. Use Right Tool**  
Don't force tools or attachment to do a job it was not designed for.
  - 12. Wear Proper Apparel**  
Do not wear loose clothing, gloves, neckties or jewelry (rings wristwatches) to get caught in moving parts. NONSLIP footwear is recommended.  
Wear protective hair covering to contain long hair. Roll long sleeves above the elbow.
  - 13. Secure Work**  
Use clamps or a vise to hold work when practical. It's safer than using your hands and frees both hands to operate tool.
  - 14. Use Safety Goggles**  
Wear safety goggles (must comply with ANSIZ87.1) at all times. Everyday eyeglasses only have impact resistant lenses, they are NOT safety glasses. Also, use face or dust mask if cutting operation is dusty, and ear protectors (plugs or muffs) during extended periods or operation.
  - 15. Don't Overreach**  
Keep proper footing and balance at all times.
  - 16. Check Damaged Parts**  
Before further use of the tool, a guard or other part that is damaged should be carefully checked to ensure that it will operate properly and perform its intended function. Check for alignment of moving parts, binding of moving parts, breakage of parts, mounting, and any other conditions that may affect its operation. A guard or any part that is damaged should be properly repaired or replaced.
  - 17. Use Recommended Accessories**  
Consult the owner's manual for recommended accessories. Follow the instructions that accompany the accessories. The use of improper accessories may cause hazards.
  - 18. Disconnect Tools**  
Before servicing; when changing accessories such as blades, bits, cutter, etc.
  - 19. Direction of Feed**  
Feed work into a blade or cutter against the direction of rotation of the blade or cutter only.
  - 20. Maintain Tools with Care**  
Keep tools sharp and clean for best and safest performance. Follow instructions for lubricating and changing blades, bits, cutters, etc.

## 21. Avoid Accidental Starting

Makes sure switch is in "OFF" position before plugging in power cord.

## 22. Never Leave Tool Running Unattended

Turn power off. Don't leave tool until it comes to a complete stop.

# Special Safety Rules for Scroll Saw

### **⚠ WARNING:**

**For your own safety, do not operate your scroll saw until it is completely assembled and installed according to the instructions ... and until you have read and understood the following:**

1. Should any part of this scroll saw be missing, bent, or fail in any way, or any electrical component fail to perform properly, shut off power switch and remove plug from power supply outlet. Replace damaged, missing, and/or failed parts before resuming operation.
2. **Think Safety**  
Safety is a combination of operator common sense and alertness whenever the scroll saw is in operation.
3. **Stability of Tool**  
Your scroll saw must be bolted securely to stand or work bench. In addition, if there is any tendency for the scroll saw to move during certain operations, bolt your scroll saw stand or workbench to the floor.
4. **Location**  
To avoid fire or explosions, never use this tool where flammable vapors or gases are in the air. To avoid injury from dropped unit, unplug saw before moving it. This scroll saw is intended for indoor use only.
5. **Protection: Eyes, Hands, Face, Ears, and Body**
  - A. To avoid being pulled into the blade:
    - Roll long sleeves above elbows
    - Do not wear gloves, jewelry, ties or other loose clothing.
    - Tie back long hair
  - B. Do not cut pieces of material too small to hold by hand outside the blade guard/hold down.
  - C. Avoid awkward hand positions where a sudden slip could cause a hand to move into the blade.
  - D. To avoid slips due to lifting of the work piece make sure the blade teeth point downward toward the table.
  - E. To avoid blade breakage always adjust blade tension correctly.
  - F. To avoid losing control of the workpiece or tool:
    - When cutting a large piece of material make sure it is fully supported at table height.
    - Hold the workpiece firmly against the table.
    - Do not feed the material too fast while cutting. Only feed the material fast enough so that the blade will cut.
    - Use caution when cutting off material which is irregular in cross section and could pinch the blade before the cut is completed. A piece of molding, for example, must lay flat on the table and not be permitted to rock while being cut.
    - Use caution when cutting off round material such as dowel rods, or tubing. They have a tendency to roll while being cut causing the blade to bite. Use a V-block to control the piece.
  - G. When backing the blade out of the workpiece, the blade may bind in the kerf (cut) .. this is usually caused by sawdust clogging up the kerf. If this happens: Turn off the

scroll saw .. remove plug from power source outlet ... wedge open the kerf ... back the blade out of the workpiece.

- H. To avoid unsupervised use or accidents due to inattention.
- Never leave the scroll saw work area with the power on, before the tool has come to a complete stop.
  - Do not perform layout, assembly or set up work on the table while the cutting tool is in operation.
  - Turn saw "OFF" and remove plug from power supply outlet before installing or removing an accessory attachment.
  - Never turn your scroll saw "ON" before clearing the table of all objects: (tools, scraps of wood, etc.) except for the work piece and related feed or support devices for the operation planned.

# Unpacking and Checking Contents

## TOOLS NEEDED FOR ASSEMBLY

COMBINATION SQUARE MUST BE TRUE

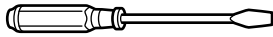

Medium Screwdriver



Phillips Screwdriver

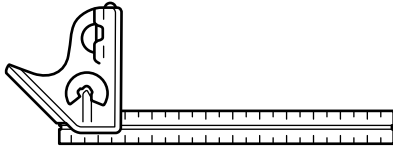

Combination square

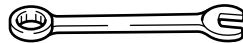

10 mm Wrench

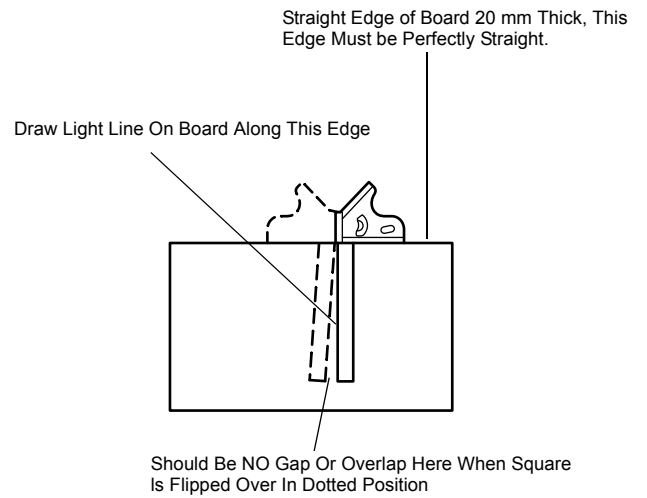

### ⚠ WARNING:

To avoid injury from unexpected starting or electrical shock, do not plug the saw in until all assembly and alignment steps are complete. The power cord must remain unplugged whenever you are working on the saw.

The scroll saw is shipped complete in one carton.

Separate all parts from packing materials and check each item with illustration and "Table of Loose Parts". Make certain all items are accounted for, before discarding any packing material.

### NOTE:

Insert the hose to air diaphragm before starting.

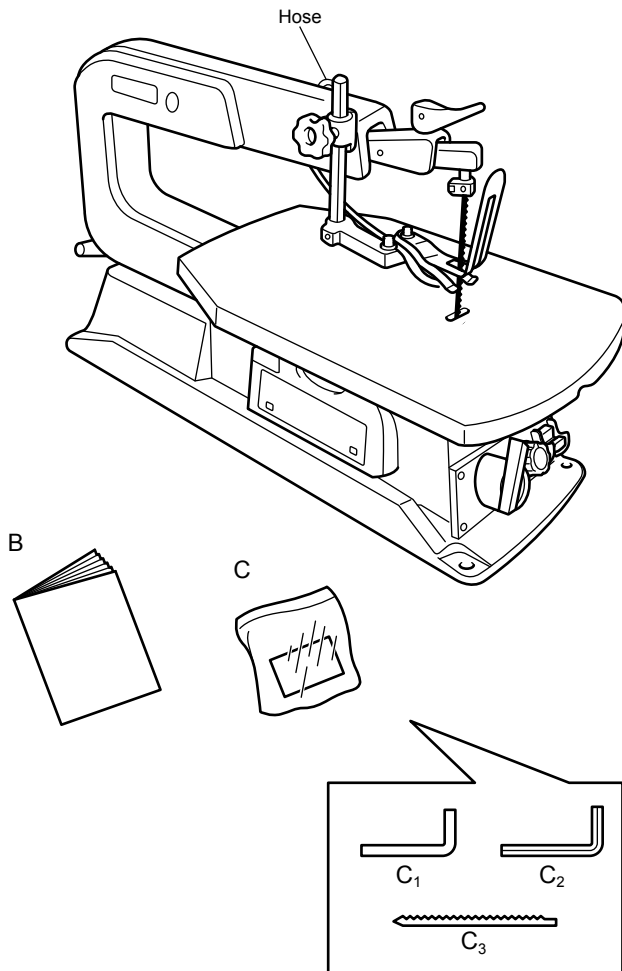

### ⚠ WARNING:

If any parts are missing, do not try to assemble the scroll saw, plug in the power cord or turn the switch on until the missing parts are obtained and installed correctly.

ITEM	TABLE OF LOOSE PARTS	QTY
A	Basic saw assembly	1
B	Owners Manual	1
C	Loose Parts Bag	
	Containing the following parts:	
C <sub>1</sub>	Blade Change Rod	1
C <sub>2</sub>	Hex Wrench "L"	1
C <sub>3</sub>	Saw blade	6

# Getting To Know Your Scroll Saw

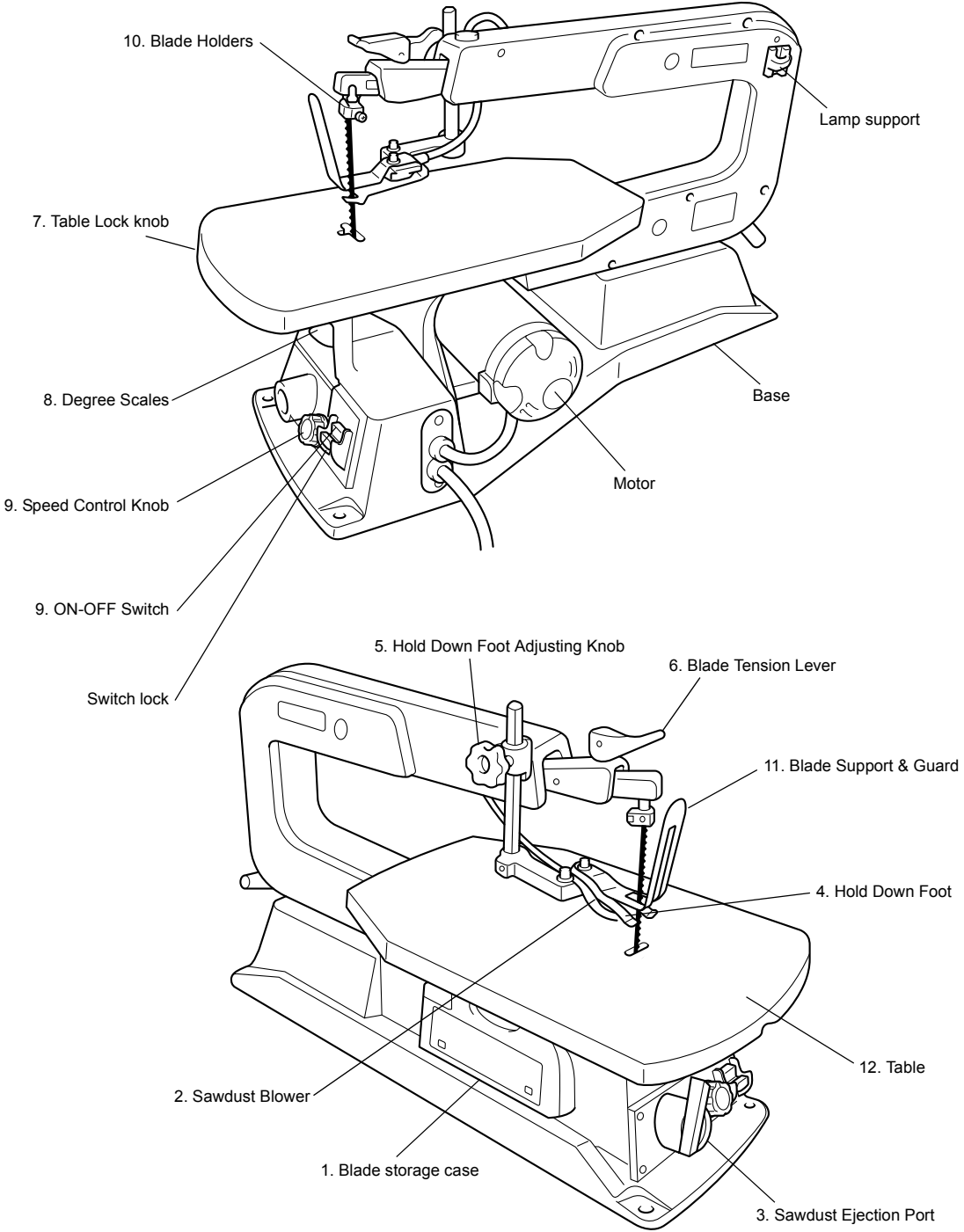

# Getting To Know Your Scroll Saw

This versatile heavy-duty scroll saw is great for making toys, puzzles, games, artwork, and jewelry, and because of its cutting capacity, it is a handy do-it-yourself tool. It cuts wood and plastic up to 50 mm thick.

## 1. Blade Storage Case

Your scroll saw is equipped with a blade storage area located on the side of the saw. The blade storage area conveniently stores the blade set screws, allen wrenches and both pin and plain end blades. **You can open the case with pressing the top.**

## 2. Sawdust Blower

Keeps workpiece clean for more accurate scroll cuts. For best results, always direct air flow from blower tube at blade and workpiece. To adjust, loosen set screw in the foot assembly, position tube and tighten screw.

CAUTION: To prevent blower tube from collapsing DO NOT OVERTIGHTEN.

## 3. Sawdust Ejection Port

Your scroll saw is equipped with a vacuum hook-up. This feature will allow you to attach any 32 mm vacuum hose into the hole provided for convenient sawdust removal.

## 4. Hold Down Foot

The foot should always be lowered until it just rests on top of the workpiece to prevent workpiece from lifting, but not so much that the workpiece drags.

## 5. Hold Down Foot Adjusting Knob

Allows you to raise or lower the foot and lock it at desired heights.

## 6. Blade Tension Lever

Allows you to loosen or tighten the blade tension by rotating the lever.

## 7. Table Lock Knob

Allows you to tilt the table and lock it at desired angle up to 45 degrees.

## 8. Degree Scale

Shows the degree the table is tilted.

## 9. Speed Control Knob/ON-OFF Switch

For speed control setting, refer to the "Choice of Blade and Speed" table. The ON-OFF Switch has a locking feature. THIS FEATURE IS INTENDED TO HELP PREVENT UNAUTHORIZED USE BY CHILDREN AND OTHERS.

## 10. Blade Holders

Retain and position the blade

## 11. Blade Support & Guard

Defines area of moving blade and supports blade

## 12. Table

Provides working surface to support workpiece.

## Trailing Edge

The workpiece edge last cut by the saw blade.

## Workpiece

The item on which the cutting operation is being performed.

# Assembly & Adjusting

## MOUNTING SCROLL SAW TO WORKBENCH

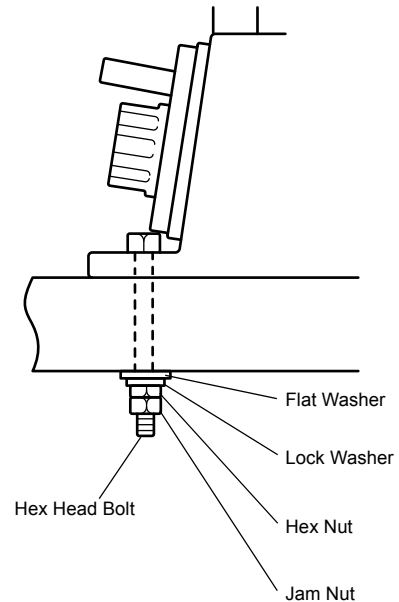

### ⚠ WARNING:

Turn off saw and unplug before making any adjustments.

1. When mounting this saw to a workbench, a solid bench is preferable to a plywood bench where noise and vibration will be more noticeable.
2. Hardware to mount this saw to a workbench is NOT SUPPLIED with the saw. However, we recommend the hardware used be no smaller than the following.

Quantity	Description
3	Hex Head Bolts, M8 Required
3	Flat Washers, 8
3	Lockwasher, 8
6	Hex Nuts, M8

3. Example of mounting this scroll saw to workbench, as shown.

# Glossary of Terms

## Kerf

The slot cut by the blade.

## Leading Edge

The edge of the workpiece which is pushed into the blade first.

## Sawblade Path

The area of the workpiece directly in line with and moving toward the saw blade edge.

## Blade Tooth Set

The distance that the edge of the saw blade tooth is bent (onset) outward from the side of the blade.

## SETTING THE TABLE FOR HORIZONTAL OR BEVEL CUTTING

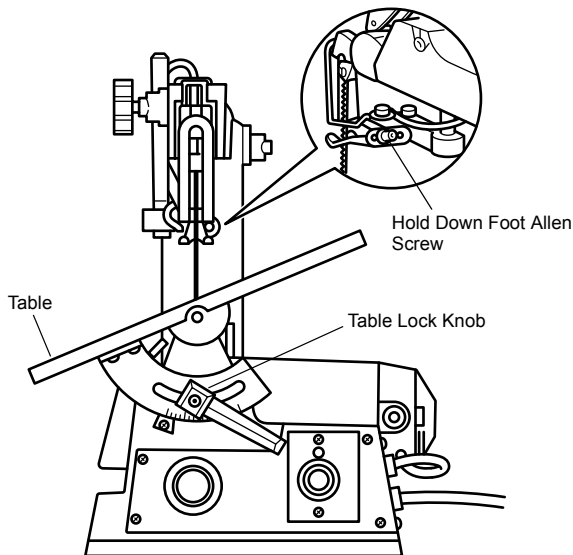

1. Loosen the table lock knob, and the saw table can be tilted to the left and locked at any angle from 0 degree horizontal cutting position up to 45 degrees for bevel cutting.
2. A degree scale is also provided under the work table as a convenient reference for setting the approximate table angle for bevel cutting. When greater precision is required, make practice cuts and adjust the table as necessary for your requirements.
3. NOTE: When cutting at angles, the hold down can be tilted so it's parallel to the table and rests flat against the workpiece. To tilt foot, loosen allen screw, tilt foot so it's parallel to table and securely tighten screw.

## ADJUSTING HOLD DOWN

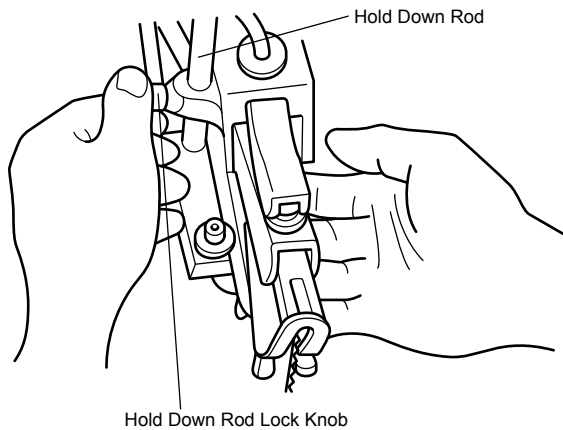

The hold down should be adjusted so it contacts the top surface of the work being cut by loosening adjusting knob and moving hold down rod up or down.

Tighten adjusting knob after adjustment has been made.

## ADJUSTING DUST BLOWER

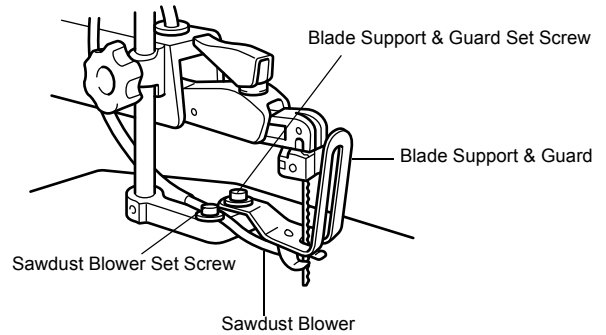

The dust blower may be moved to direct air to the most effective point on the cutting line by loosening screw, adjust dust blower accordingly and tighten screw.

## ALIGNING THE BEVEL INDICATOR

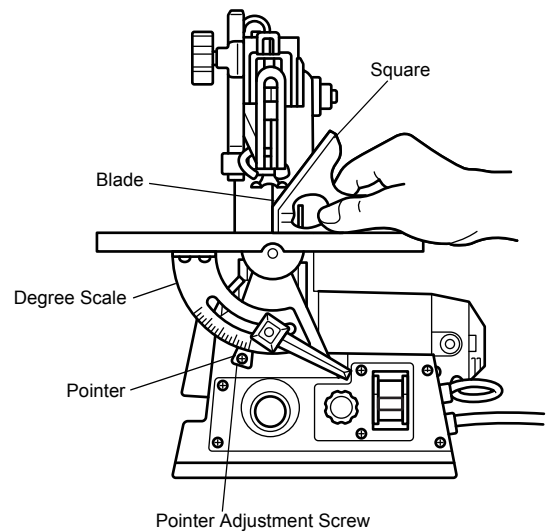

1. Loosening the hold down adjusting knob and moving hold down rod up. Then tighten adjusting knob.
2. Loosen the table lock knob and move the table until it is approximately perpendicular, or at a right angle to the blade.
3. Place a small square on the table next to the blade to check if the table is 90 degrees to the blade. If adjustment is needed, raise or lower the table until table is approximately 90 degrees to the blade and securely tighten the table lock knob.
4. Loosen the screw holding the degree scale pointer, move pointer to the 0 degree mark and securely tighten screw. Remember, the degree scale is a convenient guide but should not be relied upon for precision. Make practice cuts on scrap wood to determine if your angle setting are correct.
5. Remove the hold down rod to desired position.

## INSTALLING PIN END BLADES

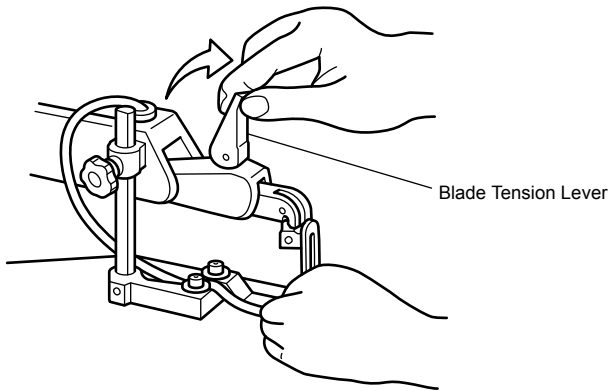

**⚠ WARNING:**  
To avoid injury from unexpected tool movement, always unplug the saw before installing, removing, or replacing the blade.

1. Unplug power cord from outlet.
2. Install blade with the tension lever in vertical position.
3. Install the blade through the insert opening. Have the teeth pointing down. Engage the pin into the "V" notch of the lower blade holder.

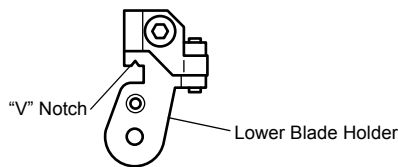

4. Pull up on the blade and engage the upper pin in the notch of the upper blade holder.

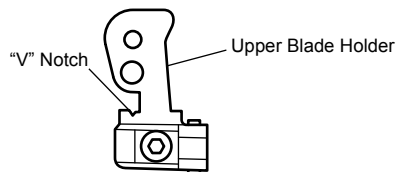

5. Flip tension lever down to horizontal position to lock in tension.

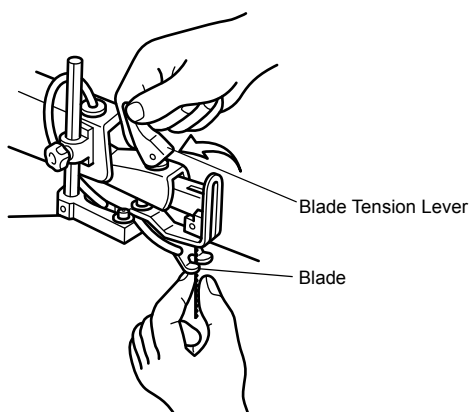

### NOTE:

For your own need, turn blade tension lever clockwise until blade is tensioned.

## INSTALLING PLAIN END BLADES

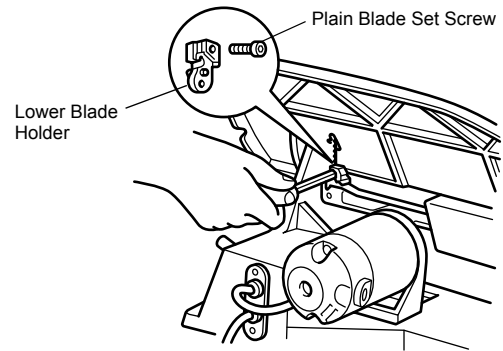

### NOTE:

For plain end blades, the set screw of the blade holders needs to be used. The set screws are supplied in the loose parts bag.

1. Unplug power cord from outlet.
2. Install blade with the tension lever in vertical position.
3. Install the new blade through the insert hole in the table, and into the lower blade holder. Position the lower end of the blade in the lower blade holder.
4. Tighten the plain blade set screw using the "L" wrench.
5. Use the same procedure to install the blade into the upper blade holder. Tighten the blade set screw using the "L" wrench, while holding the blade change rod in position.

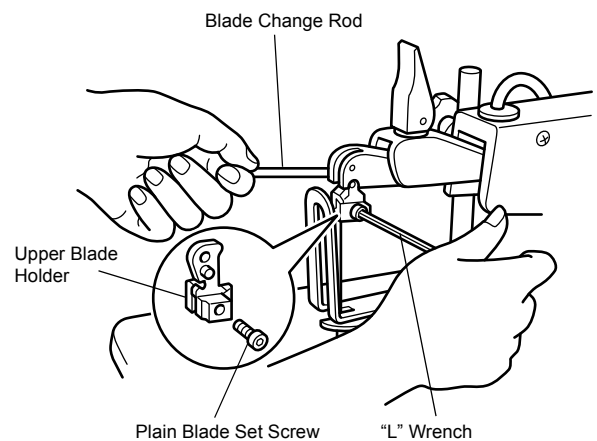

6. Remove the "L" wrench and the blade change rod from the blade holder.
7. Flip tension lever down to a horizontal position to lock in tension.
8. If necessary, turn blade tension lever clockwise until blade is tensioned.

## REMOVING PLAIN END BLADES

1. Insert the blade change rod through the hole above the blade holder and loosen the blade set screw of the blade holder with the "L" wrench.
2. Remove the blade from upper blade holder.
3. Use the same procedure to remove the blade from the lower blade holder.



**NOTE:**

Before plugging saw in, use screwdriver to turn the motor shaft at least one cycle and insure the blade is properly installed.

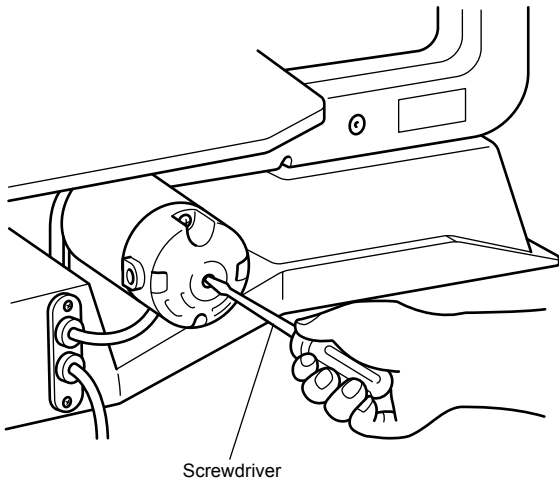
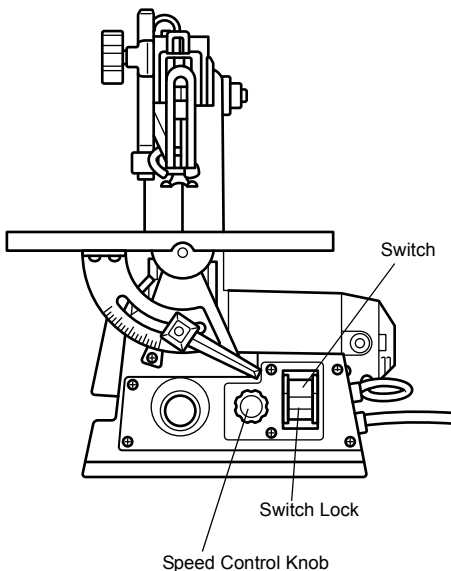
**SPEED CONTROL KNOB/ON-OFF SWITCH**

1. Turn ON switch.  
If the Switch Lock is disconnected, the Switch will not inadvertently come ON.

**Note**

- The jig saw blade does not begin to move immediately after the Switch is turned ON. This is normal, it is not a malfunction, etc.
2. The speed of the scroll saw can be changed to suit application. Turn the Speed Control Knob in the clockwise direction (↻) to increase the strokes per minute. Turn it in the anticlockwise direction (↺) to reduce the strokes per minute.
  3. Turn OFF the switch.

**Note**

- This scroll saw has a built-in overload protector. (If the jig saw blade is overworked, the motor will instantly stop to protect itself. In cases where the built-in overload protector has stopped the motor, turn OFF the ON/OFF Switch, to release the overload protector. Disconnect the machine's power plug from the power socket, remove the cut material from around the saw blade, and restart.

**Basic Scroll Saw Operation**

PLEASE, read and understand the following items about your scroll saw before attempting to use the saw.

1. Allow the saw to cut wood by guiding the wood into the blade as it moves.
2. The blade teeth cut wood ONLY on the down stroke.
3. You must guide the wood into the blade slowly because the teeth of the blade are very small and they can only remove wood on the down stroke.
4. There is a learning curve for each person who wants to use this saw. During that period of time, it is expected that some blades will break until you learn how to use the saw and receive the greatest benefit from the blades.
5. Best results are achieved when cutting wood less than 25 mm thick.
6. When cutting wood thicker than 25 mm, the user must guide the wood very, very slowly into the blade and take extra care not to bend or twist the blade while cutting.
7. Teeth on the scroll saw blades wear out and as such must be replaced frequently for best cutting results. Scroll saw blades generally stay sharp for 1/2 hour to 2 hours of cutting.
8. To get accurate cuts, be prepared to compensate for the blades' tendency to follow other wood grain as you are cutting.
9. This scroll saw is intended to cut wood or material similar to wood only.
10. When choosing a blade to use with your scroll saw, consider the following carefully.
  - Very fine, narrow blades should be used to scroll cut in thin wood 6 mm thick or less.
  - To cut wood over 6 mm thick, use wider blades.
  - Most blade packages state the size or thickness of wood which that blade is intended to cut, and the radius, size of curve, which can be cut with that blade.
  - Wider blades can't cut curves as tight or small as thinner blades.
  - Narrower blades work well only on thinner wood material.
11. This saw uses 125 mm long pin or plain end type blades.
12. Blades wear faster when cutting plywood, which is very abrasive; when sawing wood which is thicker than 20 mm blade stroke; and when sawing hardwood, or when side pressure is placed on the blade.

## MAKING INTERIOR SCROLL CUTS

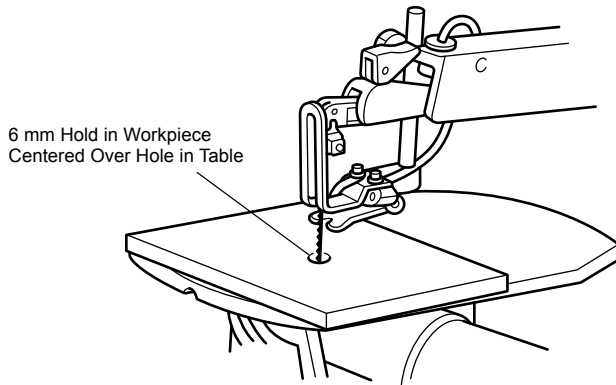

1. One of the features of this saw is that it can be used to make scroll cuts on the interior of a board without breaking or cutting into the outline or perimeter of the board.

**⚠ WARNING:**  
**To avoid injury from accidental starting, always push control knob "OFF" and remove plug from power source outlet before removing or replacing the blade.**

2. To make interior cuts in a board, remove the scroll saw blade as explain in the Assembly Section.
3. Drill a 6 mm hole in the board you will use to make interior cuts.
4. Place the board on the saw blade with the hole in the board over the access hole in the table.
5. Install blade through hole in board and adjust blade tension.
6. When finished making the interior scroll cuts, simply remove the blade from the blade holders, as described in the Assembly Section, and remove the board from the table.

### BEFORE EACH USE:

#### Inspect your saw

DISCONNECT THE SAW. To avoid injury from accidental starting, unplug the saw, push the switch "OFF" and lock the switch before changing the setup or removing covers, guards, or blade.

#### Inspect your workpiece

Make sure there are no nails or foreign objects in the part of the workpiece to be cut.

#### Use extra caution with large, very small or awkward workpieces:

- Never use this tool to cut pieces too small to hold by hand.

- Use extra supports (tables, saw horses, blocks, etc.) for any workpieces large enough to tip when not held down to the table top.
- NEVER use another person as a substitute for a table extension, or as additional support for a workpiece or to help feed, support or pull the workpiece.
- When cutting irregularly shaped workpieces, plan your work so it will not pinch the blade. A piece of molding, for example, must lay flat or be held by a fixture or jig that will not let it twist, rock or slip while being cut.
- Properly support round material such as dowel rods, or tubing. They have a tendency to roll during a cut, causing the blade to "bite". To avoid this, always use a "V" block.
- Cut only one workpiece at a time.
- Clear everything except the workpiece and related support devices off the table before turning the saw on.

#### Plan the way you will hold the workpiece from start to finish

Do not hand hold pieces so small that your fingers will go under the work hold-down. Use jigs or fixtures to hold the work and keep your hands away from the blade.

#### Before freeing any jammed material:

- Push switch "OFF".
- Lock the switch.
- Unplug the saw.
- Wait for all moving parts to stop.

#### When backing out the workpiece, the blade may bind in the kerf (cut). This is usually caused by sawdust clogging up the kerf. If this happens:

- Push switch "OFF".
- Lock the switch.
- Unplug the saw.
- Wait for all moving parts to stop.
- Remove the blade from the blade holders.
- Remove workpiece with blade from the table. Remove blade from workpiece.
- Push switch "OFF".

#### Before removing loose pieces from the table, turn saw off and wait for all moving parts to stop.

### CHOICE OF BLADE AND SPEED

The scroll saw accepts a wide variety of blade widths and thicknesses. The blade width and thickness and the number of teeth per inch are determined by the type of material and the size of the radius being cut. See the following chart.

Teeth/Inch	Width	Thickness	Speed (Strokes/Min.)	Material Cut
10	2.5 mm	0.46 mm	C (1200 - 1600)	Popular size for cutting hard and soft woods 5 mm up to 50 mm. Also plastics, paper, felt, bone, etc.
15	2.5 mm	0.46 mm	B (600 - 1200)	Wood, plastic, extremely thin cuts on materials 2.5 mm to 13 mm thick.
18	2.4 mm	0.25 mm	A (400 - 600)	For tight radius work in thin materials 3.4 mm to 3 mm wood veneer, wood, bone, fiber, ivory, plastic, etc.

As a general rule, always select the narrowest blades recommended for intricate curve cutting and widest blades for straight and large curve cutting operation.

# Maintaining Your Scroll Saw

## MAINTENANCE

**⚠ WARNING:**  
For your own safety, push control knob "OFF" and remove plug from power source outlet before maintaining or lubricating your saw.

### General

An occasional coat of paste wax on the work table will allow the wood being cut to glide smoothly across the work surface.

### Motor

If the power cord is worn, cut or damaged in any way, have it replaced immediately.

Do not attempt to oil the motor bearings or service the motor internal parts.

### Arm Bearings

Lubricate the arm bearings after 10 hours of use. Re-oil after every 50 hours of use or whenever there is squeak coming from the bearings.

### METHOD OF OILING BEARINGS

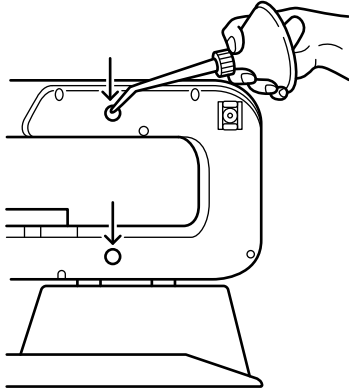

1. Turn saw on its side.
2. Squirt a generous amount of SAE20 Oil around the shaft end and bronze bearing.
3. Let the oil soak in overnight in this position.
4. Next day repeat the above procedure for the opposite side of the saw.

## WIRING DIAGRAM

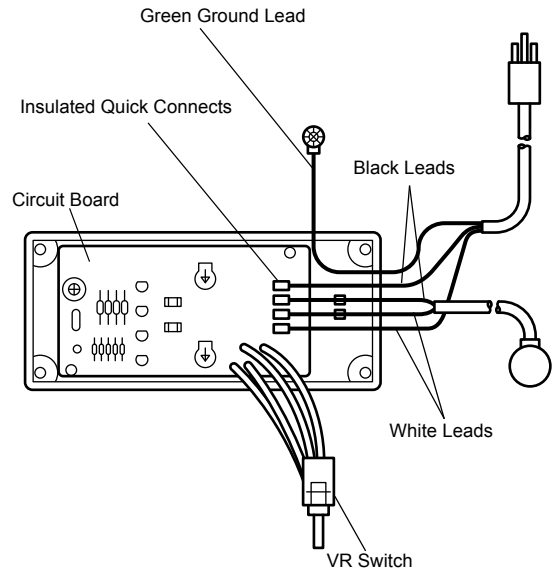

**⚠ WARNING:**  
To avoid electrocution or fire, repair electricals only with recommended service parts, and reassemble exactly as originally received when new.

# Trouble Shooting

**⚠ WARNING:**

Turn switch "OFF" and always remove plug from the power source before trouble shooting.

TROUBLE	PROBLEM	REMEDY
Breaking blades	<ol style="list-style-type: none"> <li>1. Wrong tension.</li> <li>2. Over working blade.</li> <li>3. Wrong blade application.</li> <li>4. Twisting blade in wood.</li> <li>5. Incorrect teeth per inch.</li> </ol>	<ol style="list-style-type: none"> <li>1. Adjust blade tension.</li> <li>2. Reduce feed rate.</li> <li>3. Use narrow blades for cutting thin wood, wide blades for thicker wood.</li> <li>4. Avoid side pressure on blade.</li> <li>5. Blade should have minimum 3 teeth in contact with workpiece.</li> </ol>
Motor will not run.	<ol style="list-style-type: none"> <li>1. Defective cord or plug.</li> <li>2. Defective motor.</li> <li>3. Defective wire connections.</li> </ol>	<ol style="list-style-type: none"> <li>1. Replace defective parts before using saw again.</li> <li>2. Consult Service Center. Any attempt to repair this motor may void warranty.</li> <li>3. HAZARD unless repair is done by a qualified service technician.</li> </ol>
Vibration NOTE: There will always be some vibration present when the saw is running because of motor operation.	<ol style="list-style-type: none"> <li>1. Improper mounting of saw.</li> <li>2. Unsuitable mounting surface.</li> <li>3. Loose table or table resting against motor.</li> <li>4. Loose motor mounting.</li> </ol>	<ol style="list-style-type: none"> <li>1. See "MOUNTING SCROLL SAW TO WORKBENCH".</li> <li>2. The heavier your work bench is, the less vibration will occur. A plywood workbench will not be as good a work surfaces the same size solid lumber workbench. Use common sense in choosing a mounting surface.</li> <li>3. Tighten table lock knob.</li> <li>4. Tighten motor mounting screws.</li> </ol>

**NOTE:**

Consult your local Service Center if for any reason your motor will not run.

# **MAKITA LIMITED ONE YEAR WARRANTY**

## **Warranty Policy**

Every Makita tool is thoroughly inspected and tested before leaving the factory. It is warranted to be free of defects from workmanship and materials for the period of ONE YEAR from the date of original purchase. Should any trouble develop during this one-year period, return the COMPLETE tool, freight prepaid, to one of Makita's Factory or Authorized Service Centers. If inspection shows the trouble is caused by defective workmanship or material, Makita will repair (or at our option, replace) without charge.

This Warranty does not apply where:

- repairs have been made or attempted by others;
- repairs are required because of normal wear and tear;
- The tool has been abused, misused or improperly maintained;
- alterations have been made to the tool.

IN NO EVENT SHALL MAKITA BE LIABLE FOR ANY INDIRECT, INCIDENTAL OR CONSEQUENTIAL DAMAGES FROM THE SALE OR USE OF THE PRODUCT. THIS DISCLAIMER APPLIES BOTH DURING AND AFTER THE TERM OF THIS WARRANTY.

MAKITA DISCLAIMS LIABILITY FOR ANY IMPLIED WARRANTIES, INCLUDING IMPLIED WARRANTIES OF "MERCHANTABILITY" AND "FITNESS FOR A SPECIFIC PURPOSE," AFTER THE ONE-YEAR TERM OF THIS WARRANTY.

This Warranty gives you specific legal rights, and you may also have other rights which vary from state to state. Some states do not allow the exclusion or limitation of incidental or consequential damages, so the above limitation or exclusion may not apply to you. Some states do not allow limitation on how long an implied warranty lasts, so the above limitation may not apply to you.





Makita Corporation

[www.makita.com](http://www.makita.com)

SJ401\_EN\_0610

ALA