

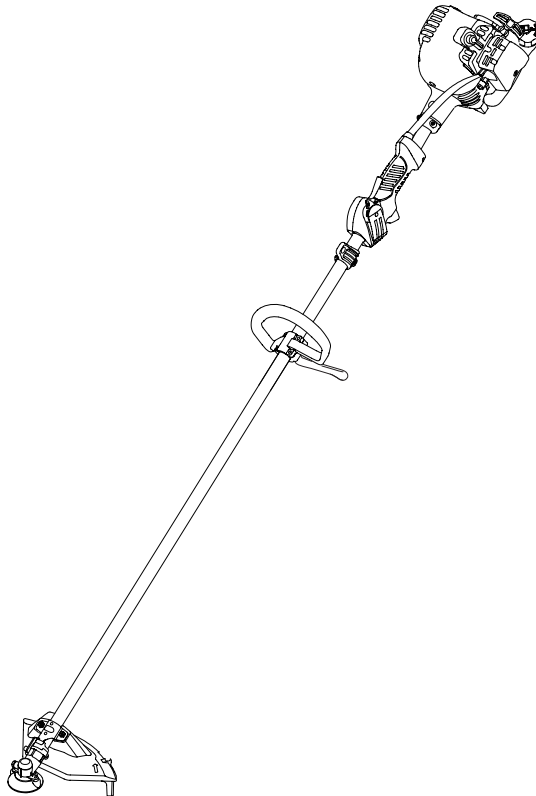

## Petrol Brushcutter

**EM2500L**

**ORIGINAL INSTRUCTION MANUAL**



**Important:**

Read this instruction manual carefully before putting the petrol brushcutter into operation and strictly observe the safety regulations!

Preserve instruction manual carefully!

















Thank you very much for purchasing the MAKITA petrol brushcutter. We are pleased to recommend to you the MAKITA petrol brushcutter which is the result of a long development program and many years of knowledge and experience. Please read this booklet which refers in detail to the various points that will demonstrate its outstanding performance. This will assist you to obtain the best possible result from your MAKITA petrol brushcutter.



| Table of Contents                                | Page |
|--|------|
| Symbols.....                                     | 2    |
| Safety instructions.....                         | 3    |
| Technical data.....                              | 7    |
| Designation of parts.....                        | 8    |
| Mounting of handle.....                          | 9    |
| Mounting of protector.....                       | 9    |
| Mounting of cutter blade/nylon cutting head..... | 10   |
| Fuels/refuelling.....                            | 11   |
| Correct handling of machine.....                 | 12   |
| Points in operation and how to stop.....         | 13   |
| Resharpener the cutting tool.....                | 14   |
| Servicing instructions.....                      | 16   |
| Storage.....                                     | 18   |

## SYMBOLS

You will note the following symbols when reading the instructions manual.

|   |   |  |  |
|---|---|--|--|
|    | Read instruction manual   |     | Wear eye and ear protection                    |
|   | Take particular care and attention  |    | Wear protective helmet, eye and ear protection |
|  | Forbidden   |  | Do not use metal blades                        |
|  | Keep distance   |   | Top permissible tool speed                     |
|  | Flying object hazard  |   | Fuel and oil mixture                           |
|  | No smoking  |   | Engine-manual start                            |
|  | No open flame   |   | Emergency stop                                 |
|  | Protective gloves must be worn  |   | First Aid                                      |
|  | Kickback  |   | START  |
|  | Keep the area of operation clear of all persons and pets                        |  |  |
|  | Wear sturdy boots with non-slip soles. Steel toed safety boots are recommended. |  |  |

# SAFETY INSTRUCTIONS

## General Instructions

- Read this instruction manual to become familiar with handling of the equipment. Users insufficiently informed will risk danger to themselves as well as others due to improper handling.
- It is recommended only to lend the equipment to people who have proven to be experienced. Always hand over the instruction manual.
- First users should ask the dealer for basic instructions to familiarize oneself with the handling of brushcutters.
- Children and young persons aged under 18 years must not be allowed to operate this equipment. Persons over the age of 16 years may however use the device for the purpose of being trained while under supervision of a qualified trainer.
- Use with the utmost care and attention.
- Operate only if you are in good physical condition. Perform all work calmly and carefully. The user has to accept liability for others.
- Never use this equipment after consumption of alcohol or drugs, or if feeling tired or ill.
- National regulation can restrict the use of the machine.

## Intended use of the machine

- This equipment is only intended for cutting grass, weeds, bushes, undergrowth. It should not be used for any other purpose such as edging or hedge cutting as this may cause injury.

## Personal protective equipment

- The clothing worn should be functional and appropriate, i.e. it should be tight-fitting but not cause hindrance. Do not wear either jewelry or clothing which could become entangled with bushes or shrubs.
- In order to avoid either head-, eye-, hand- or foot injuries as well as to protect your hearing the following protective equipment and protective clothing must be used during operation.
- Always wear a helmet where there is a risk of falling objects. The protective helmet (1) is to be checked at regular intervals for damage and is to be replaced at the latest after 5 years. Use only approved protective helmets.
- The visor (2) of the helmet (or alternatively goggles) protects the face from flying debris and stones. During operation always wear goggles, or a visor to prevent eye injuries.
- Wear adequate noise protection equipment to avoid hearing impairment (ear muffs (3), ear plugs etc.).
- The work overalls (4) protect against flying stones and debris. We strongly recommend that the user wears work overalls.
- Gloves (5) are part of the prescribed equipment and must always be worn during operation.
- When using the equipment, always wear sturdy shoes (6) with a non-slip sole. This protects against injuries and ensures a good footing.

## Starting up the brushcutter

- Please make sure that there are no children or other people within a working range of 15 meters (50 ft), also pay attention to any animals in the working vicinity.
- Before use always check the equipment is safe for operation: Check the security of the cutting tool, the throttle lever for easy action and check for proper functioning of the throttle lever lock.
- Rotation of the cutting tool during idling speed is not allowed. Check with your dealer for adjustment if in doubt. Check for clean and dry handles and test the function of the start/stop switch.

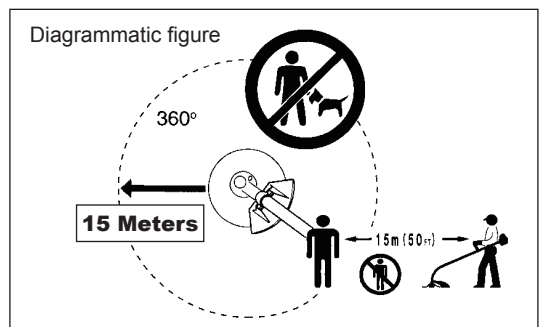
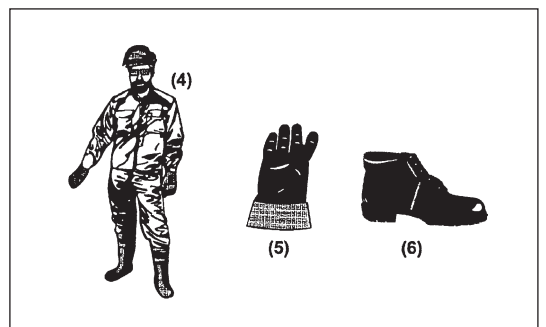
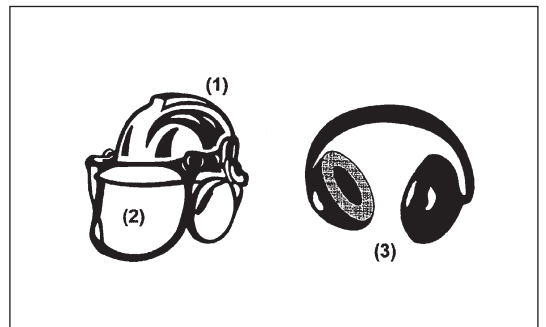
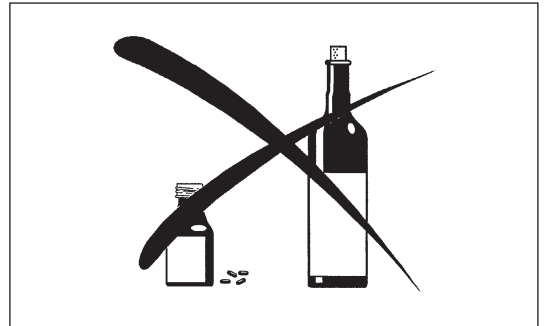
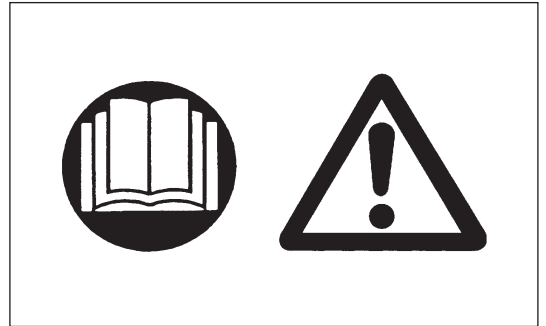

Start the brushcutter only in accordance with the instructions.

- Do not use any other methods for starting the engine!
- Use the brushcutter and the tools only for such applications as specified.
- Only start the engine, after the entire assembly is done. Operation of the device is only permitted after all the appropriate accessories are attached!
- Before starting make sure that the cutting tool has no contact with hard objects such as branches, stones etc. as the cutting tool will revolve when starting.
- The engine is to be switched off immediately in case of any engine problems.
- Should the cutting tool hit stones or other hard objects, immediately switch off the engine and inspect the cutting tool.
- Inspect the cutting tool at short regular intervals for damage (detection of hairline cracks by means of tapping-noise test).
- If the equipment gets heavy impact or fall, check the condition before continuing work. Check the fuel system for fuel leakage and the controls and safety devices for malfunction. If there is any damage or doubt, ask our authorized service center for the inspection and repair.
- Operate the equipment only with the shoulder harness attached which is to be suitably adjusted before putting the brushcutter into operation. It is essential to adjust the shoulder harness according to the user size to prevent fatigue occurring during use. Never hold the cutter with one hand during use.
- During operation always hold the brushcutter with both hands. Always ensure a safe footing.
- Operate the equipment in such a manner as to avoid inhalation of the exhaust gases. Never run the engine in enclosed rooms (risk of gas poisoning). Carbon monoxide is an odorless gas.
- Switch off the engine when resting and when leaving the equipment unattended, and place it in a safe location to prevent danger to others or damage to the machine.
- Never put the hot brushcutter onto dry grass or onto any combustible materials.
- Always install the approved cutting tool guard onto the equipment before starting the engine. Otherwise contact with the cutting tool may cause serious injury.
- All protective installations and guards supplied with the machine must be used during operation.
- Never operate the engine with faulty exhaust muffler.
- Shut off the engine during transport.
- When transporting the equipment, always attach the cover to the metal blade.
- Ensure safe position of the equipment during car transportation to avoid fuel leakage.
- When transporting, ensure that the fuel tank is completely empty.
- When unloading the equipment from the truck, never drop the Engine to the ground or this may severely damage the fuel tank.
- Except in case of emergency, never drop or cast the equipment to the ground or this may severely damage the equipment.
- Remember to lift the entire equipment from the ground when moving the equipment. Dragging the fuel tank is highly dangerous and will cause damage and leakage of fuel, possibly causing fire.

## Refueling

- Shut off the engine during refueling, keep away from open flames and do not smoke.
- Avoid skin contact with mineral oil products. Do not inhale fuel vapor. Always wear protective gloves during refueling. Change and clean protective clothing at regular intervals.
- Take care not to spill either fuel or oil in order to prevent soil contamination (environmental protection). Clean the brushcutter immediately after fuel has been spilled.
- Avoid any fuel contact with your clothing. Change your clothing instantly if fuel has been spilt on it (to prevent clothing catching fire).
- Inspect the fuel cap at regular intervals making sure that it can be securely fastened and does not leak.
- Carefully tighten the fuel tank cap. Change location to start the engine (at least 3 meters away from the place of refueling).
- Never refuel in closed rooms. Fuel vapors accumulate at ground level (risk of explosions).
- Only transport and store fuel in approved containers. Make sure the fuel stored is not accessible to children.

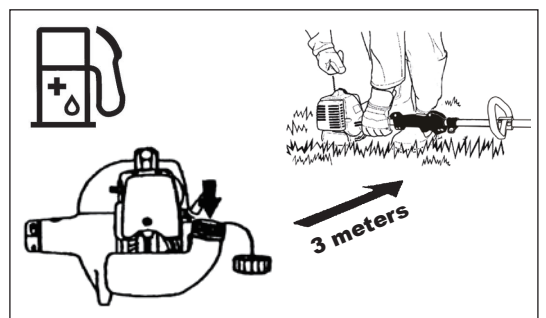
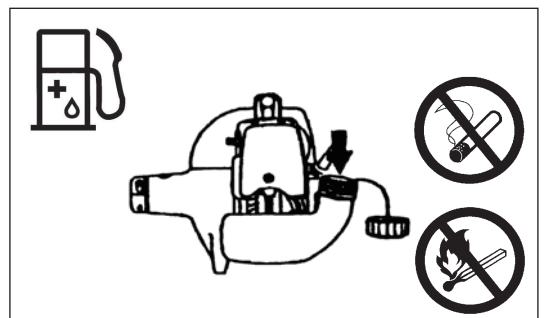
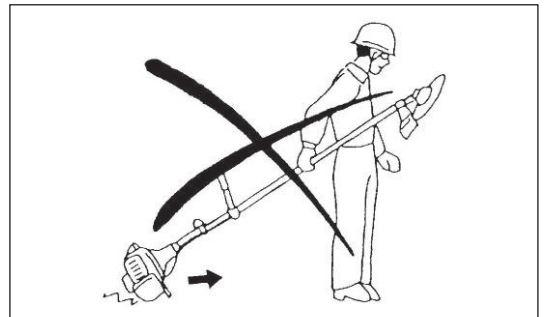
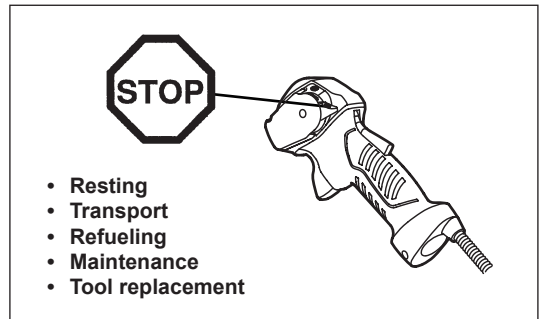
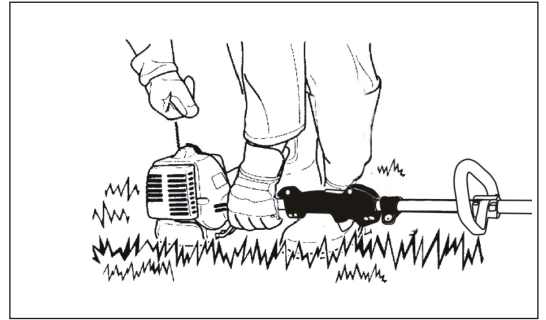

## Method of operation

- Only use in good light and visibility. During the winter season beware of slippery or wet areas, ice and snow (risk of slipping). Always ensure a safe footing.
- Never cut above waist height.
- Never stand on a ladder.
- Never climb up into trees to perform cutting operation.
- Never work on unstable surfaces.
- Remove sand, stones, nails etc. found within the working range. Foreign particles may damage the cutting tool and can cause dangerous kick-backs.
- Before commencing cutting, the cutting tool must have reached full working speed.
- When using metal blades, swing the tool evenly in half-circle from right to left, like using a scythe.  
If grass or branches get caught between the cutting tool and guard, always stop the engine before cleaning. Otherwise unintentional blade rotation may cause serious injury.
- Take a rest to prevent loss of control caused by fatigue. We recommend to take a 10 to 20-minute rest every hour.



## Cutting Tools

- Use an applicable cutting tool for the job in hand.  
Nylon cutting heads (string trimmer heads) are suitable for trimming lawn grass.  
Metal blades are suitable for cutting weeds, high grasses, bushes, shrubs, underwood, thicket, and the like.  
Never use other blades including metal multi-piece pivoting chains and flail blades. Otherwise serious injury may result.
- When using metal blades, avoid “kickback” and always prepare for an accidental kickback. See the section “Kickback” and “Kickback prevention.”

## Kickback (blade thrust)

- Kickback (blade thrust) is a sudden reaction to a caught or bound metal blade. Once it occurs, the equipment is thrown sideways or toward the operator at great force and it may cause serious injury.
- Kickback occurs particularly when applying the blade segment between 12 and 2 o'clock to solids, bushes and trees with 3 cm or larger diameter.
- To avoid kickback:
  - Apply the segment between 8 and 11 o'clock;
  - Never apply the segment between 12 and 2 o'clock;
  - Never apply the segment between 11 and 12 o'clock and between 2 and 5 o'clock, unless the operator is well trained and experienced and does it at his/her own risk;
  - Never use metal blades close to solids, such as fences, walls, tree trunks and stones;
  - Never use metal blades vertically, for such operations as edging and trimming hedges.

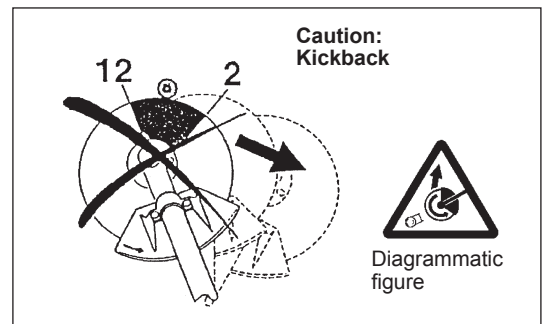

## Vibration

- People with poor circulation who are exposed to excessive vibration may experience injury to blood vessels or the nervous system. Vibration may cause the following symptoms to occur in the fingers, hands or wrists: “Falling asleep” (numbness), tingling, pain, stabbing sensation, alteration of skin color or of the skin. If any of these symptoms occur, see a physician!
- To reduce the risk of “white finger disease”, keep your hands warm during operation and well maintain the equipment and accessories.

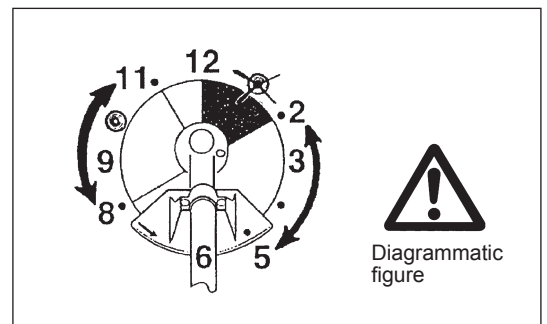

## Maintenance instructions

- Have your equipment serviced by our authorized service center, always using only genuine replacement parts. Incorrect repair and poor maintenance can shorten the life of the equipment and increase the risk of accidents.
- The condition of the cutter, in particular of the cutting tool of the protective devices and also of the shoulder harness must be checked before commencing work. Particular attention is to be paid to the metal blades which must be correctly sharpened.
- Turn off the engine and remove spark plug connector when replacing or sharpening cutting tools, and also when cleaning the cutter or cutting tool.

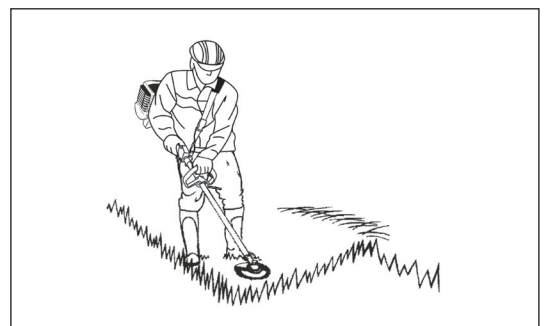

### Never straighten or weld damaged cutting tools.

- Pay attention to the environment. Avoid unnecessary throttle operation for less pollution and noise emissions. Adjust the carburetor correctly.
- Clean the equipment at regular intervals and check that all screws and nuts are well tightened.
- Never service or store the equipment in the vicinity of naked flames.
- Always store the equipment in locked rooms and with an emptied fuel tank.
- When cleaning, servicing and storing the equipment, always attach the cover to the metal blade.



Observe the relevant accident prevention instructions issued by the relevant trade associations and by the insurance companies. Do not perform any modifications to the equipment as this will endanger your safety.

The performance of maintenance or repair work by the user is limited to those activities as described in the instruction manual. All other work is to be done by an Authorized Service Agent. Use only genuine spare parts and accessories released and supplied by MAKITA. Use of non-approved accessories and tools means increased risk of accidents. MAKITA will not accept any liability for accidents or damage caused by the use of non-approved cutting tools and fixing devices of cutting tools, or accessories.

### First Aid

In case of accident make sure that a first-aid box is available in the vicinity of the cutting operations. Immediately replace any item taken from the first aid box.

### When asking for help, please give the following information:

- Place of accident
- What happened
- Number of injured persons
- Kind of injuries
- Your name

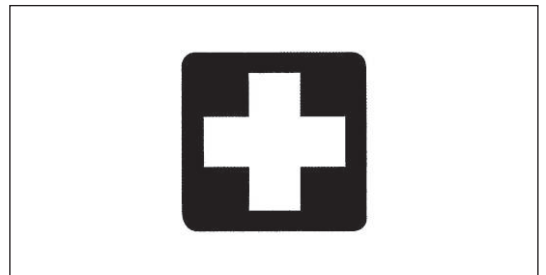

## TECHNICAL DATA EM2500L

| Model  | EM2500L  |
|--|--|
| Engine displacement                            | 24.5 cm <sup>3</sup>                                   |
| Maximum engine performance                     | 0.73 kW max.   |
| Engine speed at recommended max.               | 9,700/min max. (Blade)<br>8,200/min max. (String-head) |
| Cutting Width                                  | 230 mm (Blade)<br>430 mm (String-head)                 |
| Idling speed                                   | 3,000/min ± 100/min                                    |
| Clutch engagement speed                        | 4,100/min ± 300/min                                    |
| Gear ratio                                     | 14/19  |
| Fuel   | Mixed gas<br>Gasoline: Two-stroke Engine Oil = 50:1    |
| Volume (fuel tank)                             | 0.5 L  |
| Mass (without plastic guard and cutting blade) | 4.3 kg   |

- Due to our continuing program of research and development, the specifications herein are subject to change without notice.
- Specifications may differ from country to country.
- Weight according to EPTA-Procedure 01/2003

## DESIGNATION OF PARTS

### EM2500L Loop Handle Type

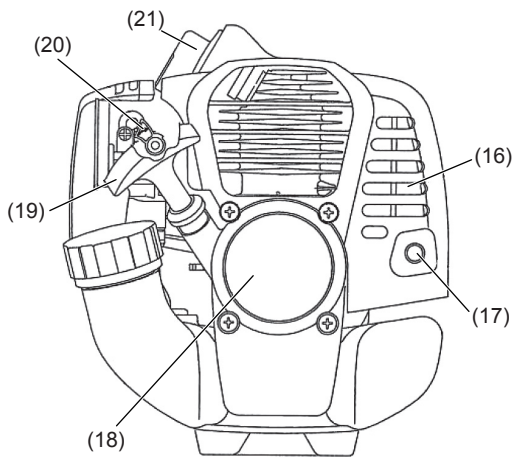
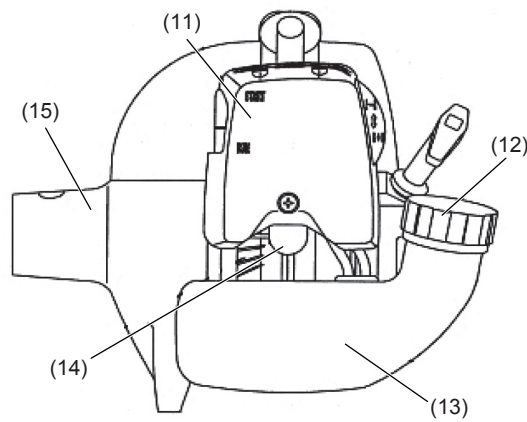
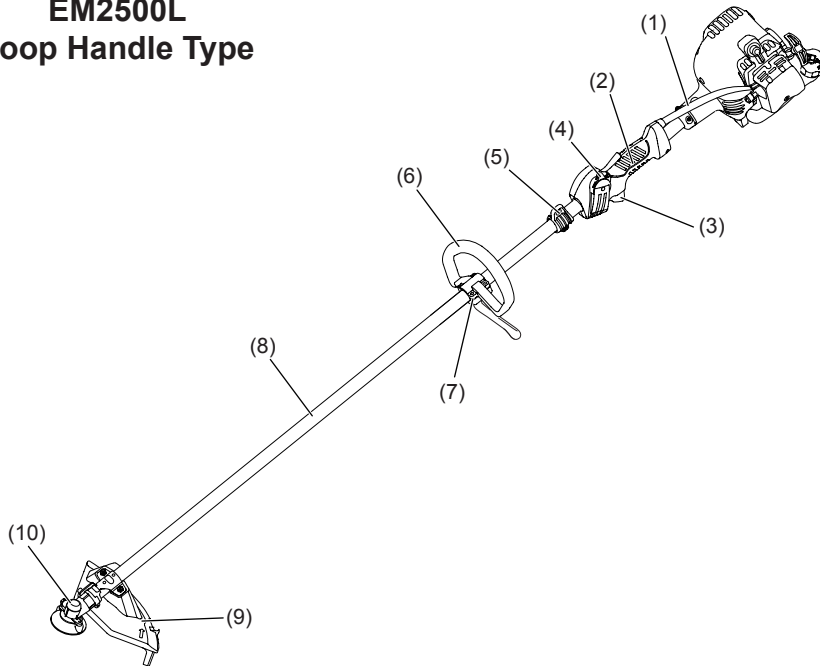

| GB | Names of parts                 |
|----|--------------------------------|
| 1  | Control Cable                  |
| 2  | Control Lever                  |
| 3  | Throttle Lever                 |
| 4  | Start-Stop Switch              |
| 5  | Hanger                         |
| 6  | Handle                         |
| 7  | Handle Holder                  |
| 8  | Shaft                          |
| 9  | Protector (Cutting Tool Guard) |
| 10 | Gear Case                      |
| 11 | Air Cleaner Cover              |
| 12 | Fuel Filler Cap                |
| 13 | Fuel Tank                      |
| 14 | Primer Pump                    |
| 15 | Clutch Case                    |
| 16 | Exhaust Muffer                 |
| 17 | Exhaust Pipe                   |
| 18 | Recoil Starter                 |
| 19 | Starter Knob                   |
| 20 | Choke Lever                    |
| 21 | Spark Plug                     |



## MOUNTING OF HANDLE

CAUTION: Before doing any work on the equipment, always stop the engine and pull the spark plug connector off the spark plug.  
Always wear protective gloves!

CAUTION: Start the engine only after having assembled it completely.

- Put the handle holder (1) and handle (2) on to the shaft.
- Make sure that the handle assembly is not fitted farther than the arrow mark (3).
- Fix and tighten them by four M5 × 30 bolts (4) and four M5 nuts (5).

Note: In some countries the handle may be non-barrier type.

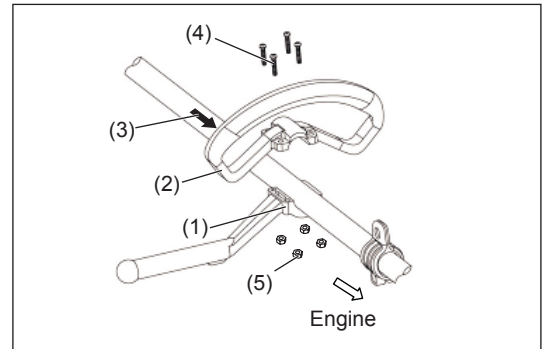

## MOUNTING OF PROTECTOR

To meet the applicable safety standards, you must only use the tool/protector combinations indicated in the table.

**Always use genuine MAKITA cutter blades/nylon cutting head.**

- The cutter blade must be well polished, and free of cracks breakages. If the cutter blade hits against a stone during operation, stop the engine and check the blade immediately.
- Polish or replace the cutter blade every three hours of operation.
- If the cutting tool hits against a stone during operation, stop the engine and check the cutting tool immediately.

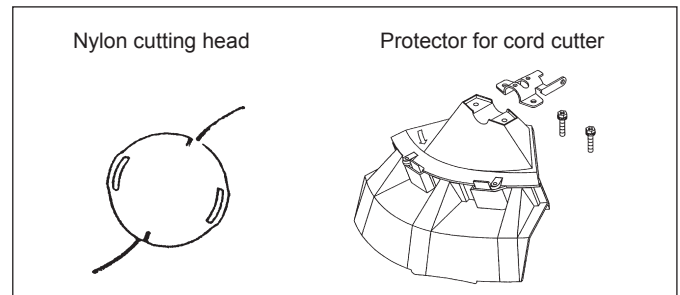
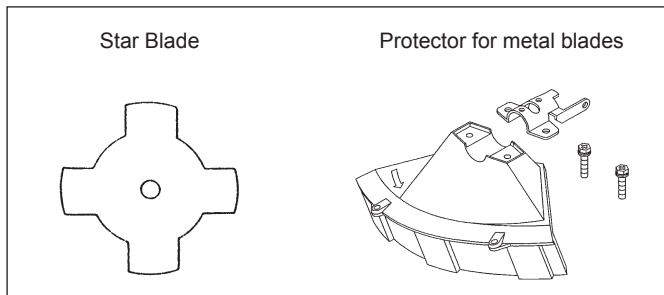

CAUTION: The appropriate protectors must always be installed for your own safety and in order to comply with accident-prevention regulations. Operation of the equipment without the guard installed is prohibited.

- Fix the protector (1) to the clamp (3) with two M6 × 30 bolts (2).

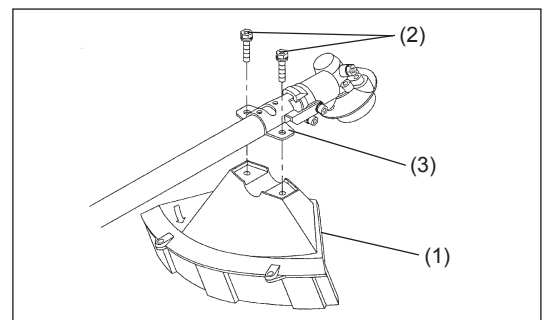

- When using the nylon cutting head, fit the protector (5) into the protector (1), and tighten them with two screws (4).

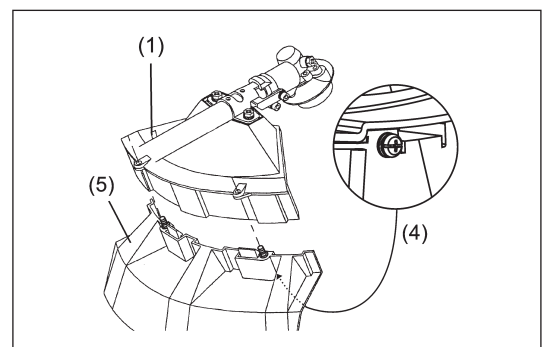

## MOUNTING OF CUTTER BLADE/NYLON CUTTING HEAD

The cutter blade or nylon cutting head can be replaced easily by first turning the equipment upside down.

- Insert the hex wrench through the hole in the gear case and rotate the receiver washer (3) until it is locked with the hex wrench.
- Loosen the nut/spring washer (1) (left-hand thread) with the socket wrench, and remove the nut/spring washer (1) and clamp washer (2).

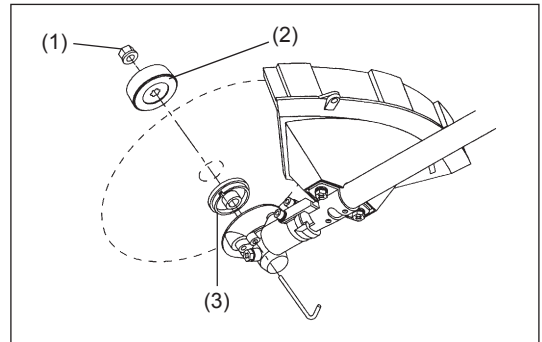

### With the hex wrench still in place

- Mount the cutter blade onto the shaft so that the guide of the receiver washer (3) fits in the arbor hole in the cutter blade. Install the clamp washer (2) and secure the cutter blade with the nut/spring washer (1). [Tightening torque: 13 – 23 N-m]

NOTE: Always wear gloves when handling the cutter blade.

NOTE: The cutter blade-fastening nut (with spring washer) is a consumable part. If there appears any wear or deformation on the spring washer, replace the nut.

NOTE: The clamp washer (2), and nut/spring washer (1) are not necessary for mounting the nylon cutting head. The nylon head should go on top of the receiver washer (3).

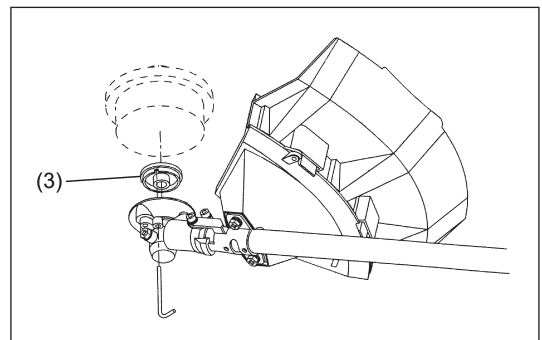
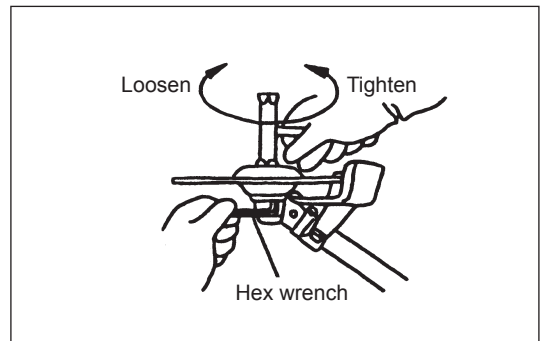

- Screw the nylon cutting head onto the shaft.

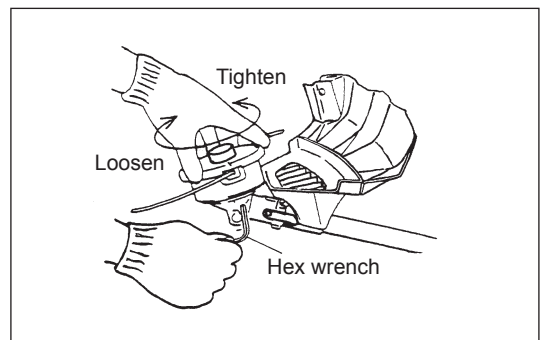

- Make sure that the blade rotates counterclockwise.

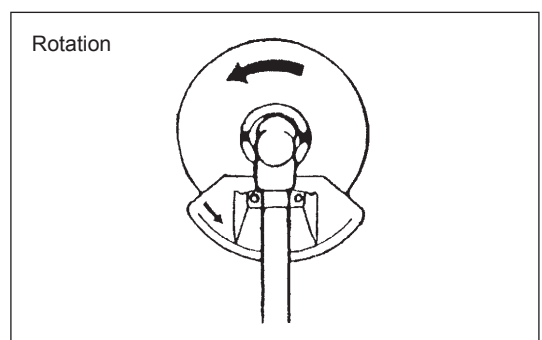



## Handling fuel

Utmost care is required when handling fuel. Fuel may contain substances similar to solvents. Refuel either in a well ventilated room or outdoors. Do not inhale fuel vapors, avoid any contact of fuel or oil with your skin. Mineral oil products degrease your skin. If your skin comes in contact with these substances repeatedly and for an extended period of time, it will desiccate. Various skin diseases may result. In addition, allergic reactions may occur. Eyes can be irritated by contact with oil. If oil comes into your eyes, immediately wash them with clear water. If your eyes are still irritated, see a doctor immediately.



Observe the Safety Instructions on page 3.

## Fuel and oil mixture

The engine of the brushcutter is a high-efficiency two-stroke engine. It is run with a mixture of fuel and two-stroke engine oil. The engine is designed for unleaded regular fuel with a min. octane value of 91 RON. In case no such fuel is available, you can use fuel with a higher octane value. This will not affect the engine, but may cause poor operating behavior. A similar situation will arise from the use of leaded fuel. To obtain optimum engine operation and to protect your health and environment, only unleaded fuel should be used!





For lubricating the engine use a two-stroke engine oil (quality grade: TC-3), which is added to the fuel. The engine has been designed to use specified two-stroke engine oil at mixture ratio of 50:1 to protect the environment. In addition, a long service life and a reliable operation with a minimum emission of exhaust gases is guaranteed. It is absolutely essential to observe a mixture ratio of 50:1 (specified 2-stroke engine oil), as otherwise reliable function of the brushcutter cannot be guaranteed.

## The correct mixture ratio:

Gasoline: Specified two-stroke engine oil = 50:1 or  
Gasoline: Other manufacturer's two-stroke engine oil = 25:1 recommended

Note: For preparing the fuel-oil mixture first mix the entire oil quantity with half of the fuel required, then add the remaining fuel. Thoroughly shake the mixture before filling it into the brushcutter tank. It is not wise to add more engine oil than specified to ensure safe operation. This will only result in a higher production of combustion residues which will pollute the environment and clog the exhaust channel in the cylinder as well as the muffler. In addition, the fuel consumption will rise and the performance will decrease.

| Gasoline  | 50:1                | 25:1  |
|---|---------------------|---|
|  | +                   |  |
| 1,000 cm <sup>3</sup> (1 liter)   | 20 cm <sup>3</sup>  | 40 cm <sup>3</sup>  |
| 5,000 cm <sup>3</sup> (5 liter)   | 100 cm <sup>3</sup> | 200 cm <sup>3</sup>   |
| 10,000 cm <sup>3</sup> (10 liter)   | 200 cm <sup>3</sup> | 400 cm <sup>3</sup>   |

## Refuelling

### The engine must be switched off.

- Thoroughly clean the area around the fuel filler cap (2), to prevent dirt from getting into the fuel tank (1).
- Unscrew the fuel filler cap (2) and fill the tank with fuel.
- Tightly screw on the fuel filler cap (2).
- Clean screw fuel filler cap (2) and tank after refuelling.

## Storage of Fuel

Fuel cannot be stored for an unlimited period of time. Purchase only the quantity required for a 4 week operating period. Only use approved fuel storage containers.

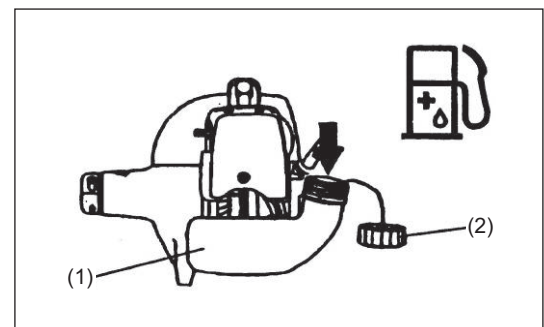

## CORRECT HANDLING OF MACHINE

### Attachment of shoulder strap

- Adjust the strap length so that the cutter blade will be kept parallel with the ground.

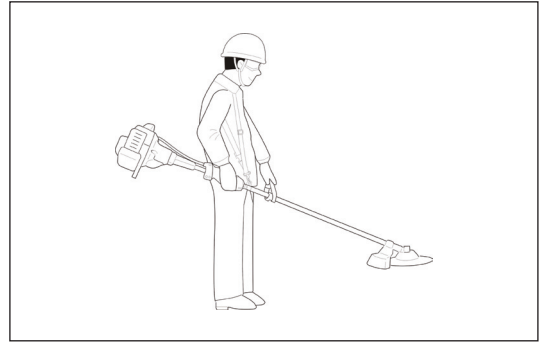

### Detachment

- This strap provides quick-release mechanism. Adjust the release button forward to the operator as shown in the illustration.

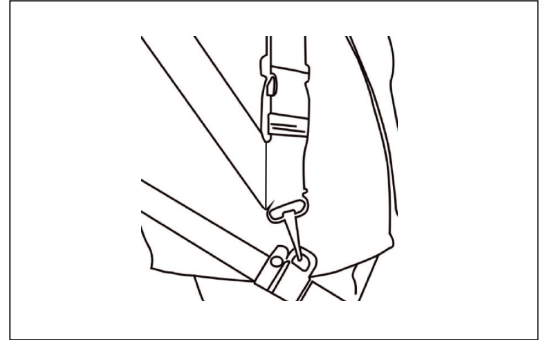

- Press the both side of the release button with one hand, the machine can be released quickly from the operator in the event of emergency (e.g. occur spark, smoking or vibrate abnormally).

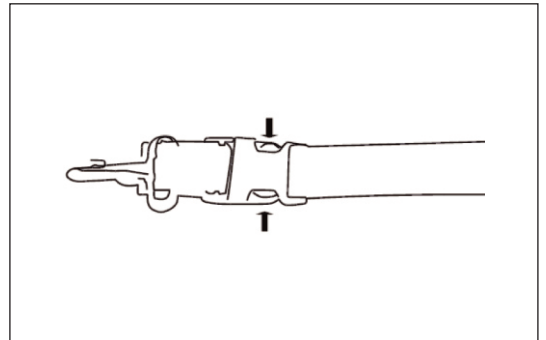

- Be extremely careful to maintain control of the machine at this time. Do not allow the machine to be deflected toward you or anyone in the work vicinity.

**⚠ WARNING:** Failure to maintain complete control of the machine at all could result in serious bodily injury or death.

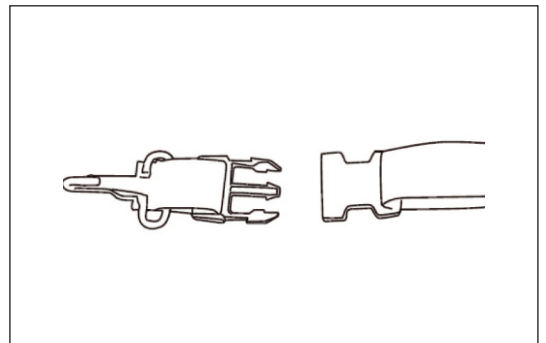

## POINTS IN OPERATION AND HOW TO STOP

Observe the applicable accident prevention regulations.

### Starting

Move at least 3 m away from the place of refuelling. Place the equipment on a clean piece of ground taking care that the cutting tool does not come into contact with the ground or any other objects.



### Cold start

- First place the equipment on the ground.
- Set the Start-Stop Switch (1) to start position.

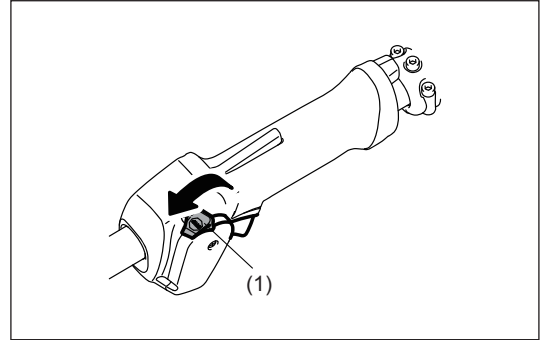

- Give a gentle push on the primer pump (2) repeatedly (7 – 10 times) until fuel comes into the primer pump.
- Push the choke lever (3) to the position “H”.

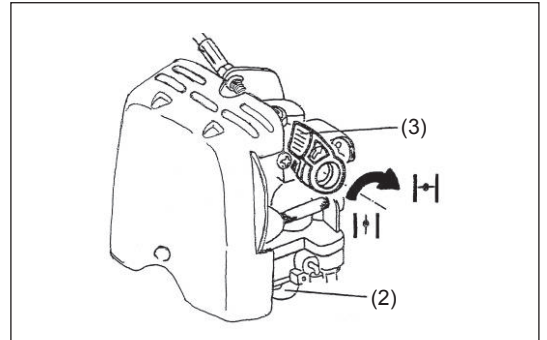

- Firmly hold the clutch case by your left hand, as illustrated.
- Slowly pull the starter knob until resistance is felt and continue with a smart pull.
- Do not pull out the starter rope to its full extent and do not allow the starter handle to be retracted without control, but ensure that it is retracted slowly.
- Repeat the starting operation until initial ignitions are heard.
- When the engine starts, return the choke lever to “III”. Please note that the choke lever will return to “III” position automatically when the throttle lever is operated and the throttle is opened.

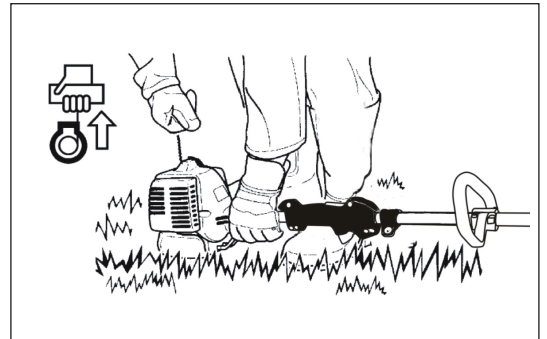

– Run the engine for approximately one minute at a moderate speed before applying full throttle.

Note: – If the starter handle is pulled repeatedly when the choke lever remains at “H” position, the engine will not start easily due to excessive fuel intake.

– In case of excessive fuel intake, remove the spark plug and pull the starter handle slowly to remove excess fuel. Also, dry the electrode section of the spark plug.

**Caution during operation:**

If the throttle lever is opened fully in a no-load operation, the engine rotation is increased to 10,000 min<sup>-1</sup> or more. Never operate the engine at a higher speed than required and at an approximate speed of 6,000 – 8,000 min<sup>-1</sup>.

**Starting the warm engine**

– Same as above, except without moving the choke lever (choke lever remains in the position “III”).

**STOPPING**

- Release the throttle lever (2) fully, and when the engine rpm has lowered, push the Start-Stop Switch (1) to “STOP” position to stop the engine.
- Be aware that the cutting head may not stop immediately, and always allow it to slow down and stop fully by itself.

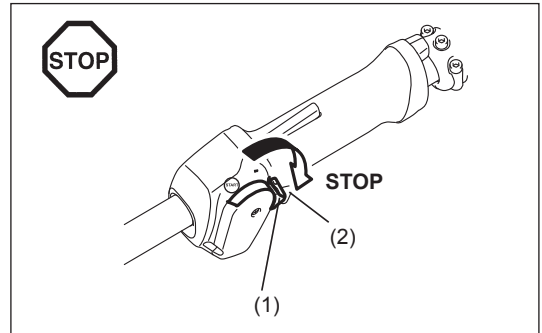

**RESHARPENING THE CUTTING TOOL**

CAUTION: The cutting tools mentioned below must only be resharpener by an authorized facility. Manual resharpener will result in imbalances of the cutting tool causing vibrations and damage to the equipment.

- cutter blade (star blade (4 teeth))  
An expert resharpener and balancing service is provided by Authorized Service Center.

NOTE: To increase the service life of the cutter blade (star blade) it may be turned over once, until both cutting edges have become blunt.

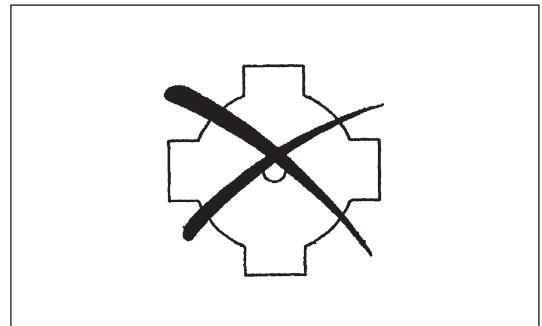

## NYLON CUTTING HEAD

The nylon cutting head is a dual line trimmer head that has bump & feed mechanism.

The nylon cutting head feeds out the nylon cord after tapping the trimmer head on the ground.

### Operation

- The most effective cutting area is shown by the shaded area.
- To feed the nylon cord, increase the nylon cutting head speed to approx. 6,000 min<sup>-1</sup> and tap the nylon cutting head lightly on the ground.
- If the nylon cutting head does not feed out by tapping, rewind/replace the nylon cord by following the procedures described under "Replacing the nylon cord."

### Replacing the nylon cord

- Stop the engine.
  - Press the housing latches inward to lift off the cover, then remove the spool.
- 
- Hook the center of new nylon cord into the notch in the center of the spool, with one end of the cord extending about 80 mm (3-1/8") more than the other. Then wind both ends firmly around the spool in the direction of the head rotation (left-hand direction indicated by LH and right-hand direction by RH on the side of the spool).
- 
- Wind all but about 150 mm (6") of the cords around the spool, leaving the ends temporarily hooked through the notch on the side of the spool.

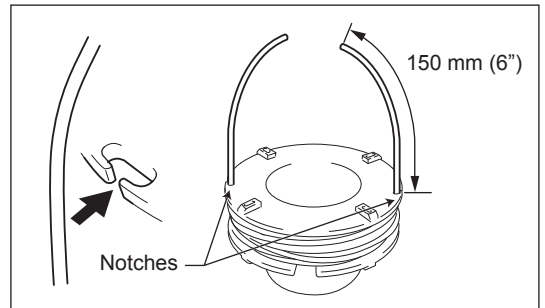
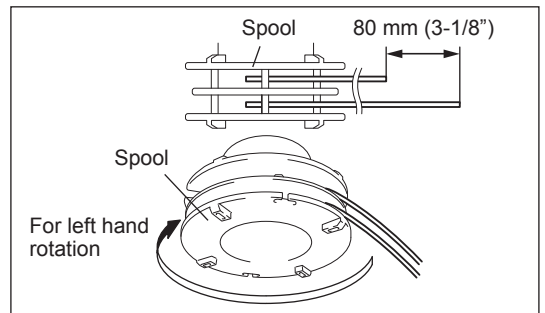
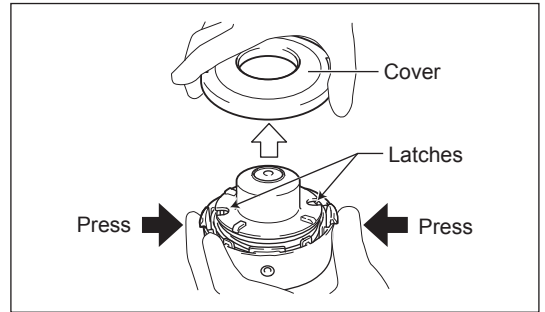
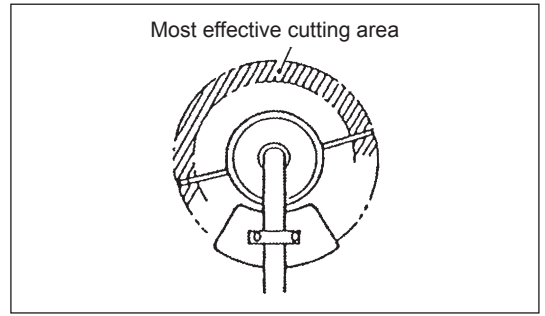

- Feed the cords through the eyelets to come out of the housing. Mount the washer, spring, and spool in the housing.

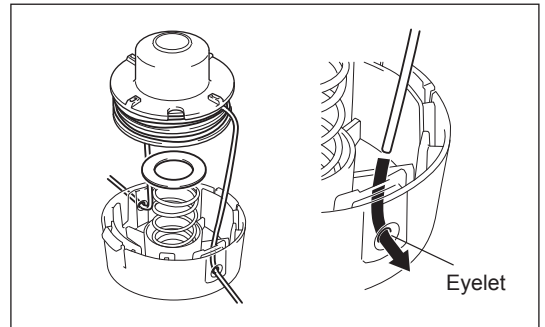

- Align the hooks on the the cover and the housing. Then push cover firmly onto the housing to secure it.

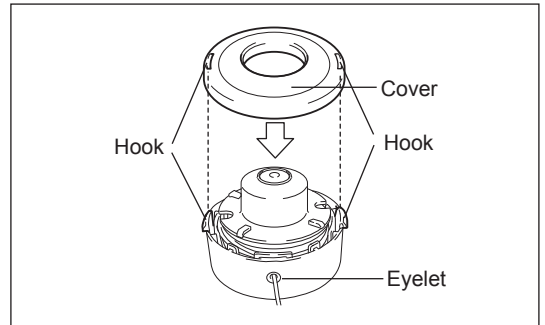

## SERVICING INSTRUCTIONS

**CAUTION:** Before doing any work on the equipment, always switch off the motor and pull the plug cap off the spark plug (see “Checking the spark plug”).

Always wear protective gloves.

**CAUTION:** Never remove the recoil starter for yourself, which may cause an accident. It should be asked to the Authorized Service Agent.



To ensure a long service life and to avoid any damage to the equipment, the following servicing operations should be performed at regular intervals.

### Daily checkup and maintenance

- Before operation, check the machine for loose screws or missing parts. Pay particular attention to the tightness of the cutting tool.
- Before operation, always check for clogging of the cooling air passage and the cylinder fins. Clean them if necessary.
- Perform the following work daily after use:
  - Clean the equipment externally and inspect for damage.
  - Clean the air filter. When working under extremely dusty conditions, clean the filter the several times a day.
  - Check the cutting tool for damage and make sure it is firmly mounted.
  - Check that there is sufficient difference between idling and engagement speed to ensure that the cutting tool is at a standstill while the engine is idling (if necessary, reduce idling speed).  
If under idling conditions the tool should still continue to run, consult your nearest Authorized Service Center.
- Check the functioning of the start-stop switch, the lock-off lever, the control lever, and the look button.

### Cleaning of air cleaner

- Remove the screw (1).
- Remove the air cleaner cover (3).
- Take out the sponge element (2), wash it in lukewarm water and dry it completely.
- After cleaning, put back the air cleaner cover (3) and fasten it with screw (1).

**NOTE:** If there is excessive dust or dirt adhering to the air cleaner, clean it every day. A clogged air cleaner may make it difficult or impossible to start the engine or increase the engine rotational speed.

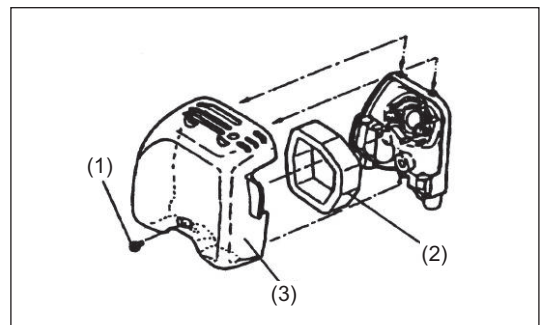



### Checking the spark plug

- Only use the supplied universal wrench to remove or to install the spark plug.
- The gap between the two electrodes of the spark plug should be 0.6 – 0.7 mm (0.024" – 0.028"). If the gap is too wide or too narrow, adjust it. If the spark plug is clogged with carbon or fouled, clean it thoroughly or replace it.

CAUTION: Never touch the spark plug connector while the engine is running (danger of high voltage electric shock).

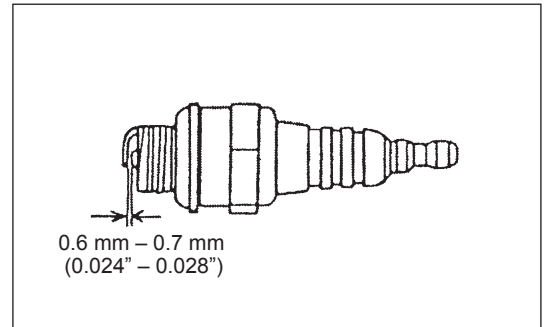

### Supply of grease to gear case

- Supply grease (Shell Alvania 2 or equivalent) to the gear case through the grease hole every 30 hours. (Genuine MAKITA grease may be purchased from your nearest authorized service center.)

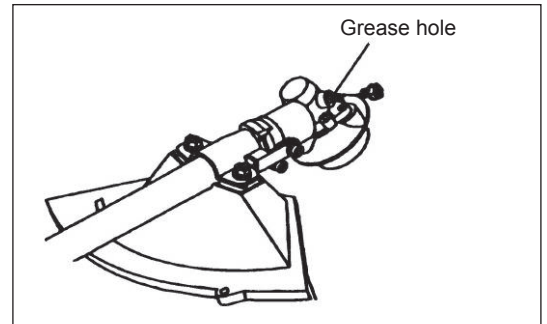

### Suction head in the fuel tank

- The fuel filter (5) of the suction head is used to filter the fuel required by the carburetor.
- A periodical visual inspection of the fuel filter is to be conducted. For that purpose open the tank cap, use a wire hook and pull out the suction head through the tank opening. Filters found to have hardened, been polluted or clogged up are to be replaced.
- Insufficient fuel supply can result in the admissible maximum speed being exceeded. It is therefore important to replace the fuel filter at least quarterly to ensure satisfactory fuel supply to the carburetor.

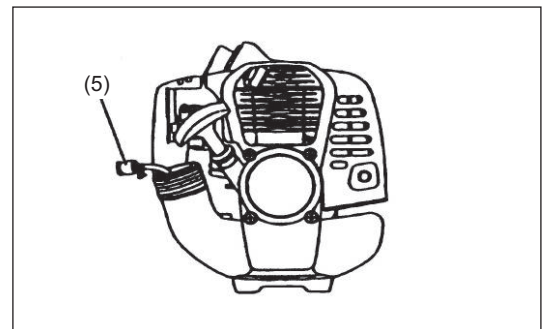

### Cleaning of muffler exhaust port

- Check of muffler exhaust port (6) regularly.
- If it is clogged by carbon deposits, carefully scratch the deposits out with a suitable tool.

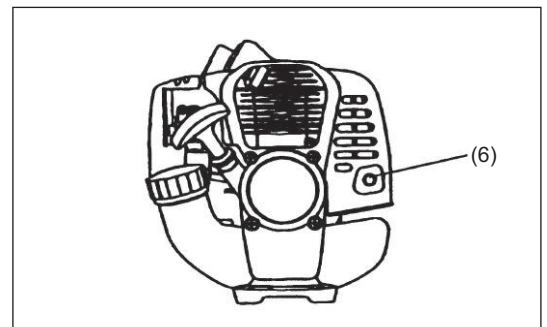

Any maintenance of adjustment work that is not included and described in this manual is only to be performed by Authorized Service Center.

## STORAGE

- When the machine is in storage for a long time, drain fuel from the fuel tank and carburetor as follows: Drain all fuel from the fuel tank. Dispose of properly and in accordance with all local laws.
- Remove the spark plug and apply a few drops of oil into the spark plug hole. Then, pull the starter knob gently, so that oil covers the engine inside and tighten the spark plug.
- Clear dirt or dust from the cutter blade and outside of engine, wipe them with a oil-immersed cloth and keep the machine in a place as dry as possible.

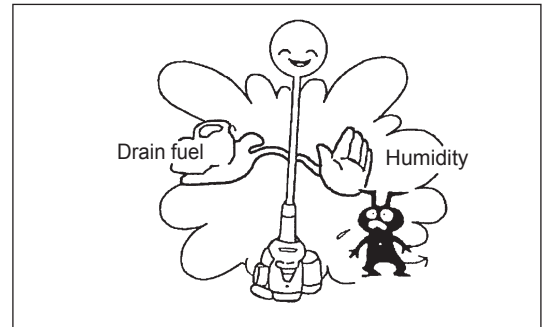

## Maintenance schedule

|                         |  |   |
|-------------------------|--|---|
| General                 | Engine assembly, screws and nuts                               | Visual inspection for damage and tightness<br>Check for general condition and security                      |
| After each refuelling   | Control lever<br>Start-stop switch                             | Functional check<br>Functional check  |
| Daily                   | Air filter<br>Cooling air duct<br>Cutting tool<br>Idling speed | To be cleaned<br>To be cleaned<br>Check for damage and sharpness<br>Inspection (cutting tool must not move) |
| Weekly                  | Spark plug<br>Muffler  | Inspection, replace if necessary<br>Check and if necessary clean the opening                                |
| Quarterly               | Suction head<br>Fuel tank                                      | To be replaced<br>To be cleaned   |
| Shutting down procedure | Fuel tank<br>Carburetor  | Empty fuel tank<br>Operate until engine runs out of fuel  |

## Fault location

| Fault                                  | System   | Observation                         | Cause   |
|--|--|-------------------------------------|---|
| Engine not starting or with difficulty | Ignition system                                | Ignition spark O.K.                 | Fault in fuel supply or compression system, mechanical defect   |
|  |  | No ignition spark                   | Start-stop switch operated, wiring fault or short circuit, spark plug or connector defective, ignition module faulty                              |
|  | Fuel supply                                    | Fuel tank filled                    | Incorrect choke position, carburetor defective, fuel supply line bent or blocked, fuel dirty  |
|  | Compression                                    | No compression when pulled over     | Cylinder bottom gasket defective, crankshaft seals damaged, cylinder or piston rings defective or improper sealing of spark plug                  |
| Warm start problems                    | Mechanical fault                               | Starter not engaging                | Broken starter spring, broken parts inside of the engine  |
|  |  | Tank filled ignition spark existing | Carburetor contaminated, must be cleaned  |
| Engine starts but dies                 | Fuel supply                                    | Tank filled                         | Incorrect idling adjustment, carburetor contaminated<br>Fuel tank vent defective, fuel supply line interrupted, cable or start-stop switch faulty |
| Insufficient performance               | Several systems may simultaneously be affected | Engine idling poor                  | Air filter contaminated, carburetor contaminated, muffler clogged, exhaust duct in the cylinder clogged   |



**Makita Corporation**  
Anjo, Aichi, Japan

[www.makita.com](http://www.makita.com)

EM2500L-ENAU-0614

ALA